



Industry Statement of Charging Interface Initiative e.V. Interoperable wireless power transfer (WPT)

Berlin, 18/05/2018



Coordination Office

CharIN e. V.

c/o innos – Sperlich GmbH
Schiffbauerdamm 12
10117 Berlin

Contact

André Kaufung

Phone: +49.30.288 8388-0

Fax: +49.30.288 8388-19

E-Mail: coordination@CharINev.org



Contents

1	Introduction	4
2	Scope	5
3	Power transfer interface	6
3.1	Power transfer requirements	6
3.2	Magnetic interoperability	7
3.3	Electric interoperability	19
3.4	Test stand description	21
4	Positioning	22
4.1	Guidance (< 6m distance)	22
4.2	Fine positioning (< 1m distance)	26
4.3	Pairing	26
4.4	Alignment Check and Monitoring	26
5	Communication interface	29
5.1	Communication structure	29
5.2	Charging process	31
5.3	Power transfer control	42
6	Safety	50
6.1	Safety concept	50
6.2	LOP/EMF	51
6.3	FOD	51
7	EMC	52
8	GA location	53
8.1	Perpendicular Reverse Parking	54
8.2	Perpendicular Forward, Angle Forward and Parallel Parking	55
9	Diagnosis	56
10	Conclusion & Next Steps	57
11	Abbreviations	58



Reference	60
Contact	60



1 Introduction

Char IN is dedicated to develop and establish the Combined Charging System (CCS) as the standard for charging Battery Electric Vehicles (BEVs) of all kinds.

Besides the existing conductive charging systems, the need for interoperable inductive charging systems becomes an urgent matter. As official standards are still in progress and affected by changes, CharIN sees a need for common guidelines supported by the industry. Therefore, this industrial position paper promotes the immediate development of interoperable inductive charging systems. This interoperability shall be ensured by describing a selection of existing technical solutions that should be applied in a product.

It is not to be seen as a competing document to standards.

Missing values will be added in future version, as they have to be verified by pending tests.



2 Scope

This industrial position paper focuses on requirements and interfaces which have to be fulfilled especially by the Ground Assembly (GA) in order to be interoperable with a conform Vehicle Assembly (VA) available in near future electric vehicles.

The industrial position paper focuses on the following topics:

- Power transfer
- Positioning
- Communication
- Safety
- EMC
- GA coil location

Especially the interface between GA and VA will be described in the following chapters and in the accompanying Open-Requirement-Specification



3 Power transfer interface

3.1 Power transfer requirements

To support developments of the next generation of the inductive charging system the OEMs need fixed parameters.

Therefore, the following requirements are determined among the CharIN participants:

Compatibility / interoperability of all Z1-Z3 classes.

This means a product GA shall support any product VA, regardless of its Z-class.

Compatibility / interoperability of all WPT 1 – WPT3 classes.

Examples:

WPT3 GA has to supply WPT2 power to a WPT2 VA.

WPT1 GA has to supply WPT1 power to a WPT3 VA.

Due to national and international measurements in 2016 /2017, CharIN will follow the approach of Test stand devices and conformance tests according to SAE J2954 RP (2017-11-27).

To ensure interoperability to all VAs, the interface has to be described. This will be done in the following chapters of magnetic and electrical interoperability.

3.2 Magnetic interoperability

The characteristics of MF_WPT are mainly governed by the topology of the coil systems used for energy transfer. As described in the chapters **Fehler! Verweisquelle konnte nicht gefunden werden.**, **Fehler! Verweisquelle konnte nicht gefunden werden.** and **Fehler! Verweisquelle konnte nicht gefunden werden.**, currently coil designs for a unipolar magnetic field are intended to be used as well as coil designs with a bipolar characteristic. Depending on specific applicational product constraints, e.g. package space, weight, mounting position, a product decision for a unipolar or bipolar coil design is made.

MF-WPT interoperability between primary devices and secondary devices is mainly determined by their magnetic and electric characteristics.

Depending on application-specific product constraints, e.g. package space, weight, mounting position, a product decision for a coaxial or transversal coil design can be made.

As interoperability between coaxial and transversal coil designs is technically feasible, the following configurations can occur:

- Coaxial (unipolar) primary device operated with coaxial (unipolar) secondary device
- Coaxial (unipolar) primary device operated with transversal (bipolar) secondary device
- Transversal (bipolar) primary device operated with transversal (bipolar) secondary device
- Transversal primary (bipolar) device operated with coaxial (unipolar) secondary device

The optimum alignment point depends on the configuration, corresponding requirements, see chapter 3.2.3.1 and chapter 8.

Magnetic interoperability is ensured by defining the requirements for the magnetic field distribution around the optimum alignment points. These magnetic field requirements need to be fulfilled by all primary devices (products and test stands).

NOTE: Secondary devices (products) can be designed accordingly, as the magnetic field distribution for the entire Z-range (100mm – 250mm) and Offset area (+/-75mm / +/-100mm) is determined.



As the shape of the magnetic field is influenced by the secondary device, it is not possible to determine one magnetic field that is valid for different secondary devices.

To define the characteristics of the magnetic field independent from the influence of secondary devices, simple test devices are applied (see Figure 3-1 and Figure 3-2). These test devices are used to verify the magnetic flux by measuring induced voltages.

The induced voltage in the test devices is measured in open circuit condition, the magnetic flux Φ generated by the excited primary device is derived by

$$U_{i_i} = j\omega\Psi; \Psi = w\Phi; |\bar{\Phi}| = \frac{U_{i_i}}{\omega w}$$

U_{i_i} = induced voltage,

$\omega = 2\pi f$; $f = 85$ kHz (nominal frequency),

w = number of secondary turns

Φ = magnetic flux generated in secondary test device

Ψ = magnetic flux linkage (including all secondary turns)

When transferring power with a product secondary device, the resulting magnetic flux is generated by applying a primary device specific current, which as consequence cannot be considered here.

A normalization for the current leads to the mutual inductance

$$M_{norm} = \frac{\Phi}{I_1}$$

I_1 = current in primary device

Note that the upper formula represents the mutual inductance normalized to one winding ($w=1$) of the test devices.

The values for the normalized mutual inductance given in this annex relate to the combination of the primary devices being tested with the test devices, respectively. A test device serves as representation of a VA with a comparable geometry.



Any primary device or test stand primary device, which shows the mutual inductance with the test devices given in this annex, is compliant with respect to magnetic interoperability.

3.2.1 Coaxial test device (unipolar)

This clause gives a description of the coaxial test devices, so that they can be easily produced.

As shown in the figures below, the test device carries three windings, each of them existing of 2 turns. Voltage measurement is performed with all three windings.

The normalized mutual inductance is derived by averaging the measured voltages of the three windings U_n , $n =$ index of winding (1, 2, 3), by

$$\bar{U} = \frac{1}{4}(U_1 + 2U_2 + U_3)$$

$$M_{norm} = \frac{\bar{U}}{w I_1 \omega}$$

$w =$ number of secondary turns = 2

with assuming that I_1 remains constant during measurement.

The test device is applied for the whole Z-range covering Z classes Z1 to Z3.

The size and structure of the test device is shown in Figure 3-1.

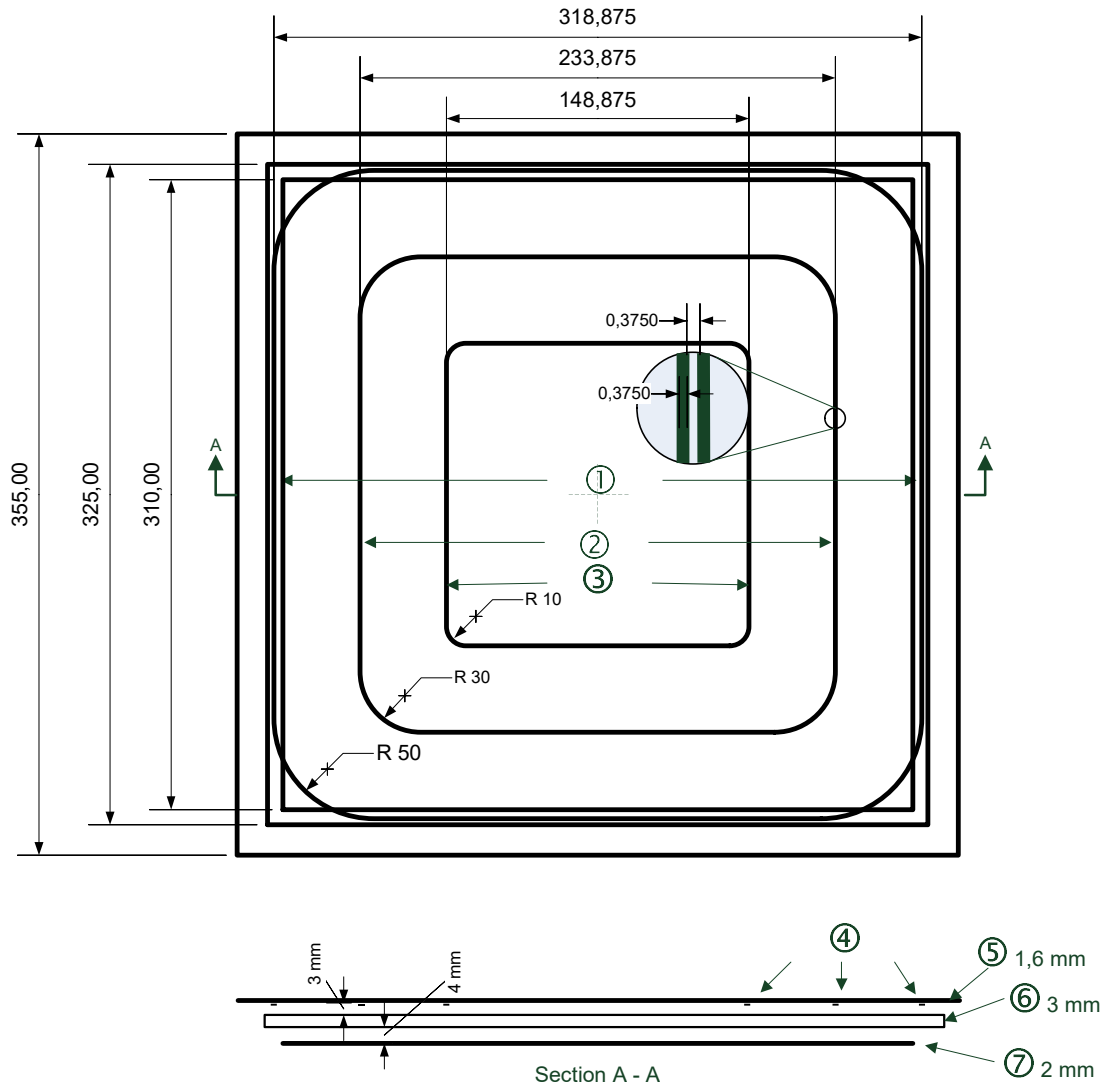

Figure 3-1 Coaxial test device, the given dimensions for the windings are related to the mid positions (i.e. between the two turns)

Key	Description
1	outer copper winding (line represents 2 turns)
2	middle copper winding (line represents 2 turns)
3	inner copper winding (line represents 2 turns)
4	PCB Copper
5	PCB GFK
6	Ferrite

7	Aluminum
---	----------

3.2.2 Transversal test device (bipolar)

This clause gives a description of the transversal test device, so that they can be easily produced.

As shown in the figure below, the secondary test device carries an 8-shaped winding consisting of 2 windings with opposite winding direction with 2 turns each. The 2 windings are connected in series connection.

The normalized mutual inductance is derived from the measured voltage U by

$$M_{norm} = \frac{U}{w I_1 \omega}$$

w = number of secondary turns = 2

with assuming that I_1 remains constant during measurement.

Note: additional test devices and related requirements will be provided in later updates.

The size and structure of the test device is shown in Figure 3-2 **Fehler! Verweisquelle konnte nicht gefunden werden.** The left windings and the right winding have to be connected in series with opposite winding direction as this is sketched in Figure 3-3.

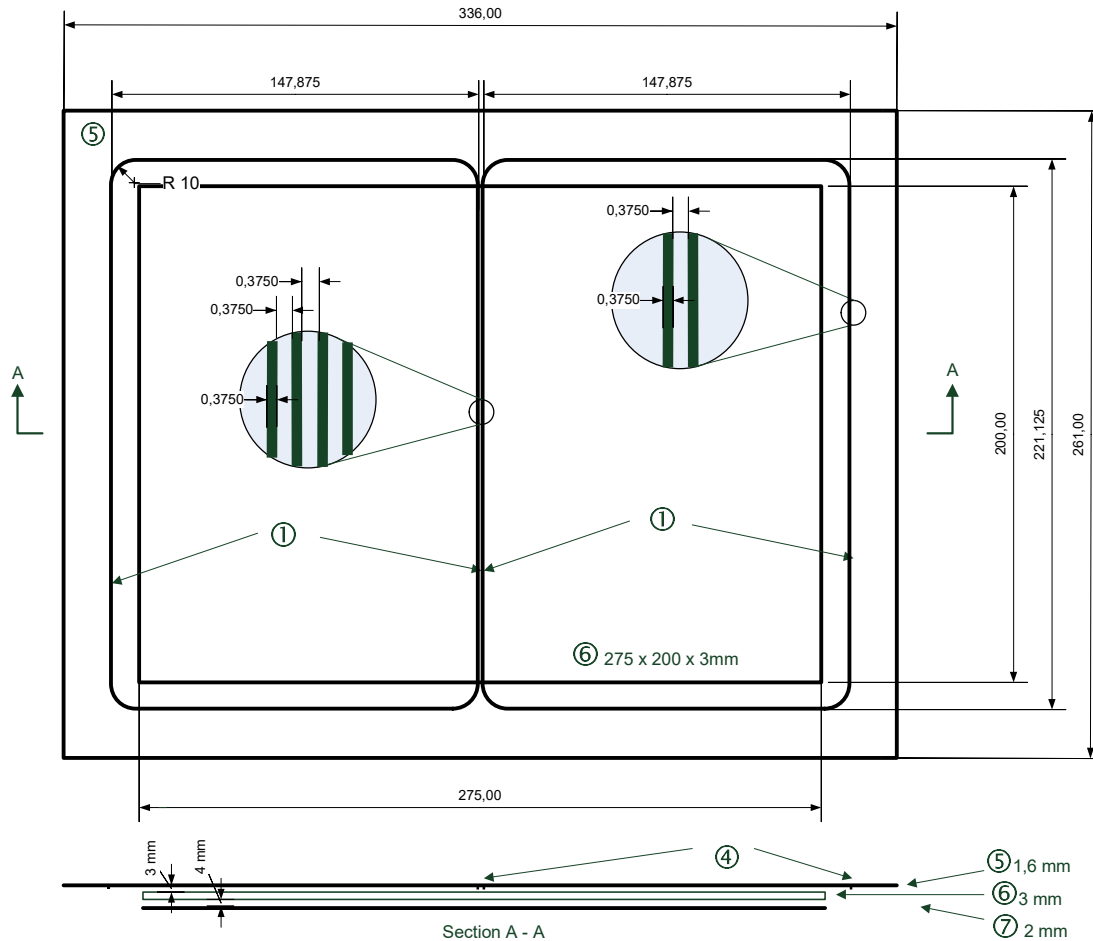

Figure 3-2 Transversal test device, the given dimensions for the windings are related to the mid positions (i.e. between the two turns)

Key	Description
1	Copper winding (line representing 2 turns)
4	PCB copper
5	PCB GFK
6	Ferrite
7	Aluminium

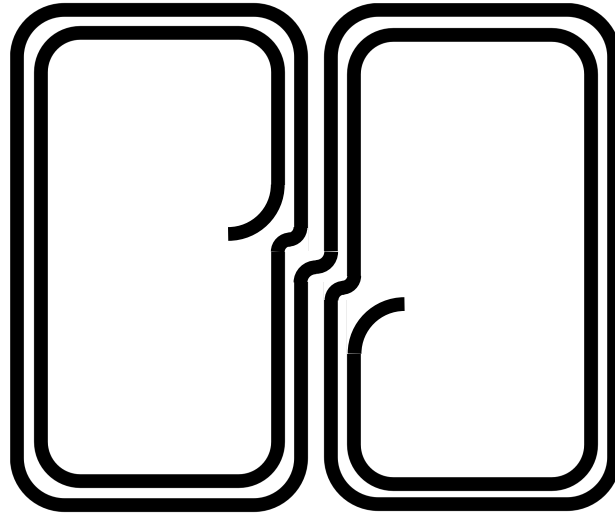

Figure 3-3 Design of winding for the transversal test device

3.2.3 Requirements for magnetic interoperability with respect to the test devices

3.2.3.1 General

The test devices described in clause 3.2.1 and 3.2.2 are used to derive the requirements for magnetic interoperability.

Optimum alignment point requirements

A primary device shall provide at least one optimum alignment point for coaxial magnetic field power transfer for usage by coaxial secondary devices.

A primary device shall provide at least one optimum alignment point for transversal magnetic field power transfer for usage by transversal secondary devices.

The dipole at the optimum alignment point for transversal magnetic field power transfer shall be orientated along the x-direction.

The positions of the optimum alignment points shall be exchanged between SECC and EVCC via communication.

The positions of the optimum alignment points shall have the same y-coordinate position.

The distance of the optimum alignment position shall be maximum of 30cm.

3.2.4 Mutual inductance requirements

Since the mutual inductance differs for different air gaps, the requirements are given according to the Z-classes Z1 – Z3.

3.2.4.1 Z1 mutual inductance

A primary device shall provide a mutual inductance with test devices specified in clauses 3.2.1 and 3.2.2 around the coaxial and transversal optimum alignment points as given in Table 1

Table 1 Mutual inductance values for Z1

z-position	(x,y) position	Coaxial mutual inductance [μH]		Transversal mutual inductance [μH]	
		CC primary device	DD primary device	CC primary device	DD primary device
Z1 _{min} = 100 mm	Nominal position (0,0)	1,43	1,500	2,674	3,763
Z1 _{max} = 150 mm	Nominal position (0,0)	0,904	0,877	1,492	2,320
Z1 _{min} = 100 mm	Offset position (100,75)	1,177	0,945	1,633	3,107
Z1 _{max} = 150 mm	Offset position (100,75)	0,686	0,599	1,030	1,792
Z1 _{min} = 100 mm	Offset position (-100,-75)	1,088	1,090	1,676	3,067
Z1 _{max} = 150 mm	Offset position (-100,-75)	0,639	0,614	0,939	1,766

3.2.4.2 Z2 mutual inductance

A primary device shall provide a mutual inductance with test devices specified in clauses 3.2.1 and 3.2.2 around the coaxial and transversal optimum alignment points as given in Table 2.

Table 2 Mutual inductance for Z2

z-position	(x,y) position	Coaxial mutual inductance [μH]		Transversal mutual inductance [μH]	
		CC primary device	DD primary device	CC primary device	DD primary device
Z2 _{min} = 140 mm	Nominal position (0,0)	0,988	0,972	1,663	2,544
Z2 _{max} = 210 mm	Nominal position (0,0)	0,528	0,479	0,804	1,359
Z2 _{min} = 140 mm	Offset position (100,75)	0,758	0,655	1,123	1,979
Z2 _{max} = 210 mm	Offset position (100,75)	0,392	0,354	0,625	1,041
Z2 _{min} = 140 mm	Offset position (-100,-75)	0,705	0,688	1,049	1,950
Z2 _{max} = 210 mm	Offset position (-100,-75)	0,371	0,315	0,495	1,030

3.2.4.3 Z3 mutual inductance

A primary device shall provide a mutual inductance with test devices specified in clauses 3.2.1 and 3.2.2 around the coaxial and transversal optimum alignment points as given in Table 3.

Compliance is tested by voltage measurement at open circuit with the transversal test device.

Table 3 Mutual inductance for Z3

z-position	(x,y) position	Coaxial mutual inductance [μH]		Transversal mutual inductance [μH]	
		CC primary device	DD primary device	CC primary device	DD primary device
Z3 _{min} = 170 mm	Nominal position (0,0)	0,754	0,716	1,207	1,937
Z3 _{max} = 250 mm	Nominal position (0,0)	0,371	0,322	0,546	0,967
Z3 _{min} = 170 mm	Offset position (100,75)	0,565	0,502	0,868	1,481
Z3 _{max} = 250 mm	Offset position (100,75)	0,277	0,250	0,452	0,747
Z3 _{min} = 170 mm	Offset position (-100,-75)	0,530	0,491	0,756	1,462
Z3 _{max} = 250 mm	Offset position (-100,-75)	0,264	0,202	0,328	0,741

3.2.5 Conformance test and measurement specifications

The conformance test may be applied either for test stand supply device or product supply device in order to declare magnetic interoperability.

The supply devices are tested in order to provide the mutual inductance values given in clause 3.2.4.

The measurements can be performed by low voltage measurements. However, the primary current magnitude for I_1 should exceed $1 A_{\text{peak}}$.

3.2.5.1 Low voltage measurement procedure:

1. Place the test device at the specific test position using the testbed as described in SAE J2954 RP (2017-11-27)
2. Set the input voltage level for the supply device to an adequate value at the measurement point (5) (see Figure 3-4). Take care that the voltage has sinusoidal shape with 85 kHz.
3. Measure the coil current I_1 of the primary device at measurement point (5) (see Figure 3-4)
4. Measure the open circuit voltage of the three windings of the test device at measurement point (8) (see Figure 3-4).
5. Calculate the average value of the three voltages and the mutual inductance according to the formulas given in 3.2.1 and the mutual inductance according to the formula given in 3.2.2, respectively.

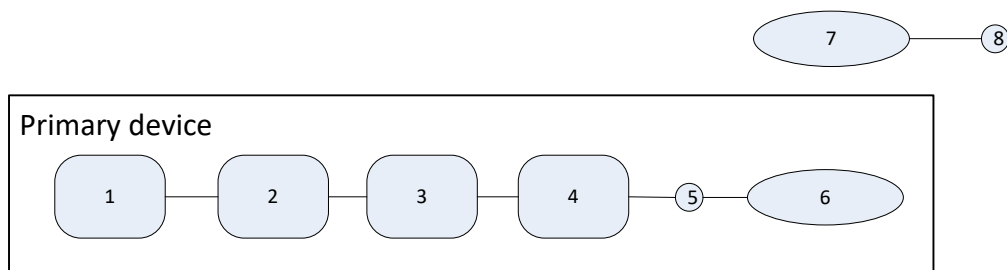

Figure 3-4 Position of measurement points

Key table:

Key	Description
1	Grid connection
2	PFC / DC power
3	Inverter
4	Filter
5	Measurement point for primary device
6	Primary device coil structure
7	Test device
8	Measurement point for test device

3.3 Electric interoperability

The requirements for electric interoperability are described in SAE J2954 RP (2017-11-27) annex G.

This clause describes parameters for system interoperability to ensure interoperability between systems from different manufacturers, Z-classes, power classes and different coil topologies.

In addition, this clause provides an example for a test bench setup for interoperability tests of product VAs.

The chapter is applicable to product primary and product secondary devices, but also for reference primary and secondary devices. It is intended to be a generic approach that is not dependent on any coil topology or any specific electronic configuration.

In addition to this annex, a product GA test is defined in this document.

3.3.1.1 Product GA test

To ensure that a product GA matches all requirements concerning interoperability, a test must be performed to prove the GA complies with the impedance constraints outlined in this annex.

The component test could be performed with the following schematic test bench setup.

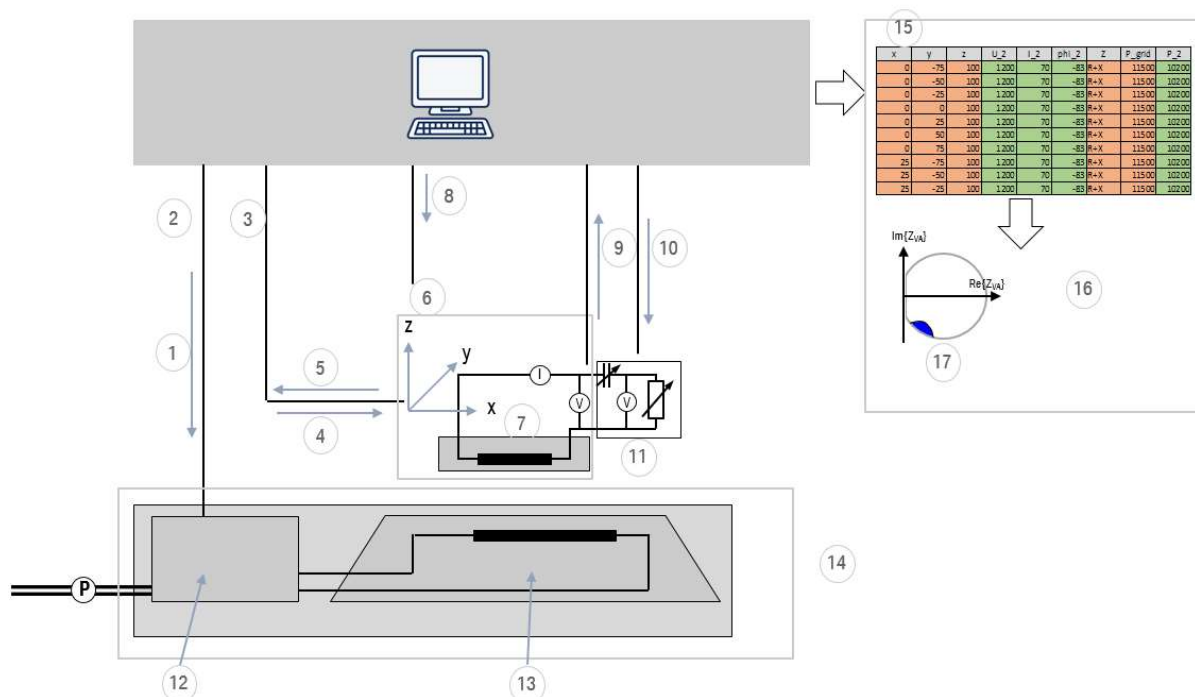

Figure 3-5 Exemplary test bench setup for GA interoperability tests

Number	Description
1	Command power
2	WIFI communication
3	CAN communication
4	If necessary; command matching etc
5	Power received etc
6	Moveable table
7	Test stand VA coil
8	Command x,y,z-offset
9	Measured U, I, φ
10	Command Z
11	Adjustable load
12	GA electronics
13	GA coil
14	Product GA, DUT
15	Report (measured data etc)
16	Calculate efficiency, worst case analysis, safety margins
17	Check interoperability

The DUT, a product GA, is plugged to the power connection and controlled via WIFI-communication by a test-bench computer that cycles through all required operation points. The test-bench computer also steps, for each set of operation points, through all required (x,y,z) positions. Further, the test-bench computer goes through the to be defined VA reference impedance zone ($Z_{VA,ref}$) –values, measures if the set impedance is reached and thereafter measures the transferred power. If power with a GA efficiency μ greater than 92% can be delivered to VA for all impedances, the product GA has shown interoperability. This test must be conducted successfully for all test stand VAs.

Test procedure

- 1) Operation points are set
 - a) P_{DC} within WPT class
 - b) $Z_{VA} = \ll TBD \gg$. VA reference impedance zone ($Z_{VA,ref}$) -values
 - c) U_{VA} , I_{VA} , φ_{VA} are measured and compared with set Z_{VA} for conformance
- 2) Measurement for all alignment positions with each step 1.
 - a) Z_{min} , Z_{max}
 - i) $(x,y) = (0,0), (0,75), (100,0), (100,75)$
- 3) Measurement of transferred power

Test criteria:

If power with efficiency greater than $\mu = 92\%$ can be delivered to VA for all operation points, all offset positions and all test stand VAs.

→ Tested GA is interoperable

If power with efficiency less than μ can be delivered to VA for one or more set Z_{VA} -impedances.

→ Tested product GA is **NOT** interoperable at that power level.

3.4 Test stand description

Test stand device shall be according to J 2954 RP (2017-11-27).

Magnetic interoperability shall be tested according to clause 3.2.

Electric interoperability shall be tested according to clause 3.3.

Performance testing shall be according to J 2954 RP (2017-11-27).



4 Positioning

Regarding positioning this industry statement has the same positioning tolerance requirements as defined in SAE J2954 recommended practice (2017-11-27).

The minimum accuracy of the overall systems at the final position shall be +/- 20 mm for x-axis and +/- 30 mm for y-axis. To improve robustness of the positioning system an accuracy of +/- 10 mm in x- and y-axis is recommended.

The cycle time for new position data shall be at maximum 180ms. The overall delay time including the transmission from the EV antennas over receiving on infrastructure side and sending back values by WiFi to EVCC shall also be at maximum 180ms.

For the positioning, the car sends the positioning signal in the range of 19-300kHz. The GA detects said signal and sends measurement results back to the car. With this information, the car calculates its position relative to the GA. The SECC has to ensure that environmental and aging influences are eliminated by fulfilling an internal calibration process with reference data.

4.1 Guidance (< 6m distance)

The LF signal is a digitally modulated magnetic field operating at the very low frequency and low frequency ITU radio bands (LF and VLF).

The sensors operate at fixed frequencies in a frequency range between 19kHz and 300kHz.

It shall be possible to use three frequencies with the system. Currently, the frequencies 104kHz, 114kHz, 145kHz, 185kHz, 225kHz are under investigation.

Note: The values of the frequencies should be chosen considering that no interference with other systems (e.g. keyless entry system) occurs.

Note: The different frequencies are needed in order to allow the LF signal for positioning of 3 EVs in parallel without interference.



The magnetic field is generated by at least two antennas, which are located at the EV. For backward parking four antennas are recommended. The mounting positions at the EV is not specified so that the position of the antennas is up to the manufacturer. It is recommended to keep a distance between the antennas of 750mm for usage with a positioning system. For forward parking it is recommended to place the EV antennas in the area of the front bumper. For rearwards parking it is advised to integrate two antennas in the area of the rear bumper.

Note: The positions of the antennas are exchanged between the EV and the supply device by communication.

The primary device contains at least four magnetic sensors with a minimum distance of 300mm to each other and whose sensing elements are placed symmetrically at least 15 mm above the aluminum plate of the primary device. The sensors should be placed in the field of the corners. The sensor quality should have a resolution of 1 nT with 5% accuracy. The sensors shall be able to receive magnetic field strength in x, y, and z direction. The receiving sensitivity should be at least 0,25nT. The measurement has to be done simultaneously for all directions. A sampling rate of 250Hz - 1kHz is under consideration.

The field strength is measured by the receivers to provide localization.

Positioning with LF signal

The frequency for a certain parking spot is chosen by the SECC and is reported to the EV via the WLN link. The EV will transmit the corresponding trigger signals to the primary device sensors at that chosen frequency.

The SECC will send back the RSSI values received by the sensors

The positioning algorithm, based on the RSSI feedback from the magnetic primary device sensors will run in the EV.



- EV requests fine positioning using the method LF
- The SECC requests the supply device to turn on the receiver
- The SECC responds to the EV with the frequency to use.
- The EV turns on the transmitter and starts at the specified frequency.
- The driver moves the EV into the parking (charging) spot.
- As the secondary device gets within at least 4 m of the primary device, the receiver should be able to detect the signals transmitted by the EV.
- The EV will send LF-signals for positioning to the primary device and will request pre-calibrated raw data from the SECC.
- The measured values are transmitted via WLN by SECC to the vehicle in the form of pre-calibrated raw data.
- From this measured values the vehicle calculates dynamically the position of the primary device.
- Once the primary and secondary devices are in “good” alignment, the EV should stop and park.
- The EV will request the end of fine positioning.
- The supply device will turn off the receiver and respond to the EV that the fine positioning is no longer active.

For the guidance, the following information needs to be exchanged. Especially in order to make proper comparison of the signals detected at the antennas of the primary device the positions of the antennas shall be exchanged between SECC and EVCC via communication over WLN.

Data of the antenna arrangement at EV to send to SECC

Element name	Description
Number of sensors at EV	Number of antennas of the auxiliary antenna system installed at the EV
For each sensor: Identifier	Identifier of the antenna
Antenna position	x,y,z coordinates of the antenna give in EV coordinates relative to the center of the secondary device given in mm
Antenna orientation	x,y,z,unit vector given the direction of measurement. If no direction is applicable, all three values are set to zero.
Pulse sequence order	Ordered list of the antenna identifiers, which describes the order with which the antennas send out a signal as one pulse package. The list defines a pulse package, which contains the ordered collection of pulses from each EV antenna.
Pulse separation time	Time in ms between the individual pulses of within the pulse package
Pulse duration	Time duration in ms of each individual pulse within the pulse package
Package separation time	Time in ms between two subsequent pulse packages
Alignment offset	Offset of the optimum alignment point in mm (in x-direction) which results from the coil design of EV and infrastructure.

Data of the antenna arrangement at primary device to send to EVCC

Element name	Description
Response code	Response code indicating that the request was processed (un)successfully.
Number of sensors at infrastructure	Number of sensors of the fine positioning system installed at the primary device.
For each sensor: Identifier	Identifier of the sensor
Sensor position	x,y,z coordinates of the sensor given in primary device coordinates relative to the center of the primary device given in mm.
Sensor orientation	x,y,z,unit vector given the direction of measurement. If no direction is applicable, all three values are set to zero.
Alignment offset	Offset of the optimum alignment point in mm (in x-direction) which results from the coil design of EV and infrastructure.
Signal frequency	Frequency in Hz of the signal to be used by the EV. (Note: for distinguishing signals coming from different EVs simultaneously, each EV needs to send its signal with a different frequency)
Pulse sequence order	Ordered list of the antenna identifiers, which describes the order with which the antennas send out a signal as one pulse package. The list defines a pulse package, which contains the ordered collection of pulses from each EV antenna.
Pulse separation time	Time in ms between the individual pulses of within the pulse package
Pulse duration	Time duration in ms of each individual pulse within the pulse package
Package separation time	Time in ms between two subsequent pulse packages



4.2 Fine positioning (< 1m distance)

The LF System can be used as well for Fine positioning under 1 m distance.

Same procedure like in the chapter 'guidance'.

4.3 Pairing

The pairing should be done according to IEC61980-2 DTS with LPE.

Optionally Pairing could be done with LF Signal:

- EVCC requests pairing using LF Signal
- SECC agrees and provides a coding pattern to be used for pairing by the EV
- The EV emits the LF Signal by applying the coding pattern,
- The supply device receives the signal and compares
- SECC returns the result to the EVCC (confirms Pairing)

If the pairing is successful, then the SECC will communicate the ID of the primary device to the EVCC as part of the pairing message sequence.

4.4 Alignment Check and Monitoring

4.4.1 Alignment check

For the alignment check the offset shall be checked with the Guidance System described in 6.1. The calculation for the alignment check can be done on infrastructure side. If the Guidance System reports a position within the Offset Area reduced by the recommended accuracy the alignment shall be confirmed by LPE according to IEC61980-2 DTS.

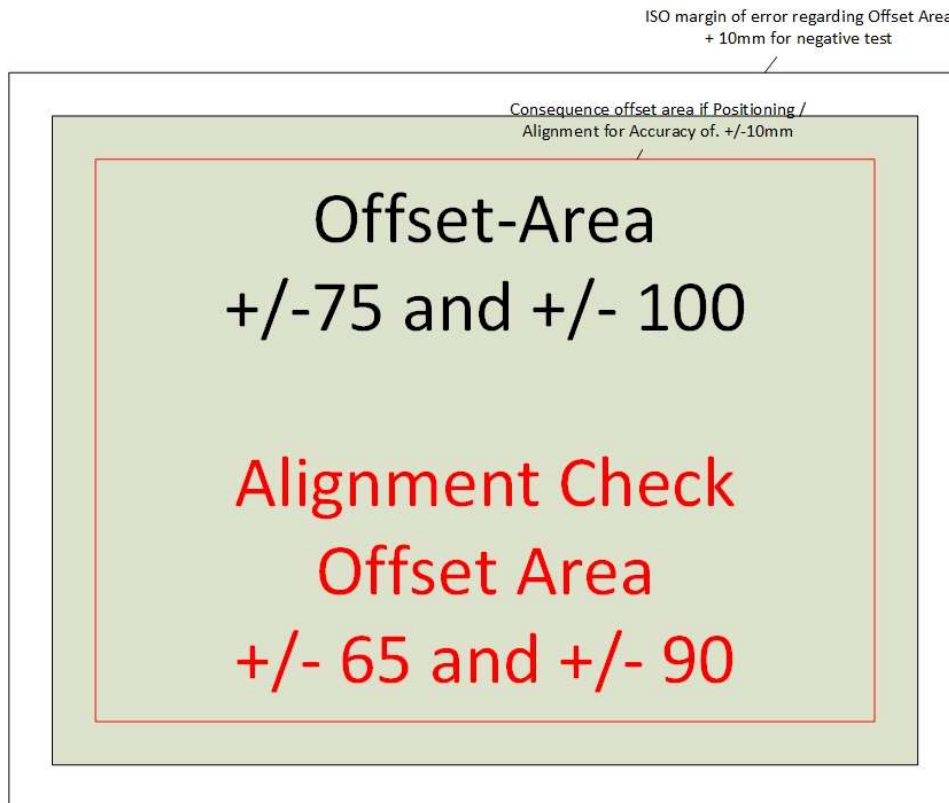

Figure 4.1 Alignment Check Offset Area

4.4.2 Alignment Monitoring

If the initial alignment check has been confirmed and power transfer started the alignment shall be monitored checked continuously by the inductive power transfer on GA side - an example is given below. If relevant parameters change more than tbd % per 200 ms (tbd) the GA shall shut-off the electromagnetic field.

If time is not safety relevant the GA shall shut-off within 2000 ms.

Example:

- EVCC requests continuous alignment check using GA detection
- The GA captures the ratio of reactive power to effective power during power transfer



- Both sides should communicate changes which have an impact on the ratio
e.g. compensation to avoid shut down

5 Communication interface

5.1 Communication structure

The communication structure shall be based on ISO15118-8 and IEC61980-2 DTS clause 5.

The following description is informative – in case of differences the respective norms are valid.

<< WiFi, SR signal, LPE, ISO 15118 usage >>

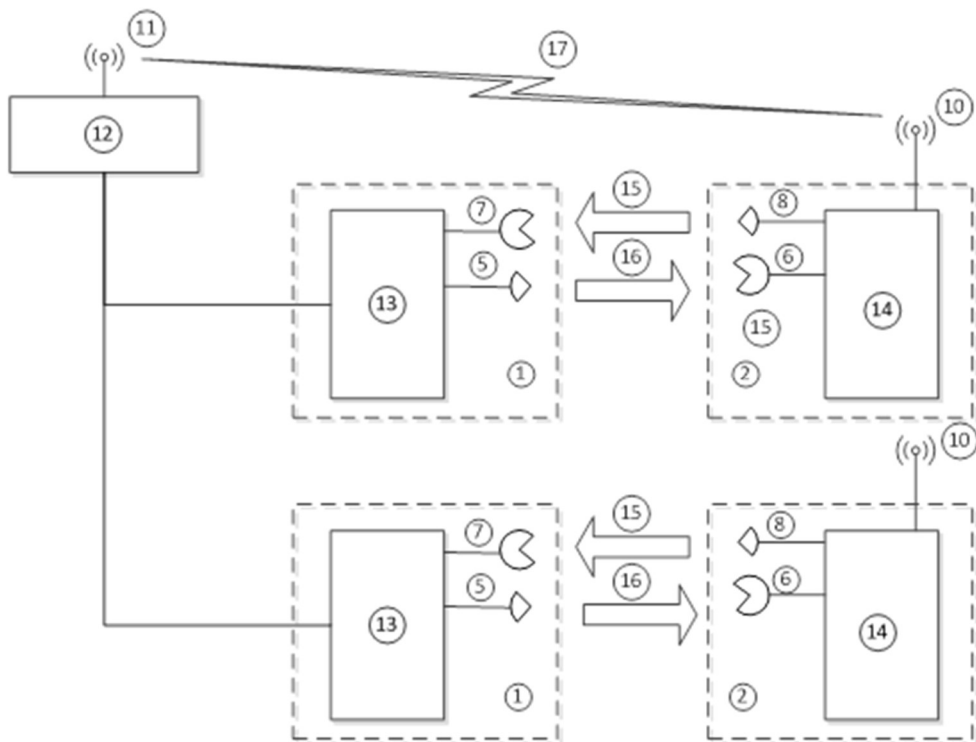

Figure 5-1 Communication topology for multiple supply devices with a joint SECC

Key	Name	Abbreviations
1	Supply device	
2	Electric vehicle	EV
5	Primary device communication controller signaller	PDCC signaller
6	Secondary device communication controller detector	SDCC detector
7	Primary device communication controller detector	PDCC detector
8	Secondary device communication controller signaller	SDCC signaller

9	Primary device communication controller WLN antenna	PDCC WLN antenna
10	Secondary device communication controller WLN antenna	SDCC WLN antenna
11	Supply equipment communication controller WLN antenna	SECC WLN antenna
12	Supply equipment communication controller	SECC
13	Primary device communication controller	PDCC
14	Secondary device communication controller / Electric vehicle communication controller	SDCC/EVCC
15	EV Signal, implemented as SR Signal	P2PS
16	SE Signal, implemented as LPE	P2PS
17	Wireless local network, implemented according to ISO 15118-8	WLN
NOTE 1 Key list also applies to Figure 5-2		

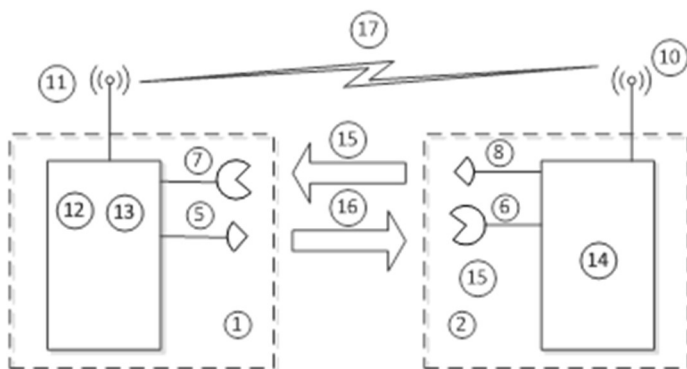

Figure 5-2 Communication topology for a single charging spot

5.2 Charging process

It is recommended to follow the description of the state machine with the transitions as described in IEC 61980-2 DTS clause 7. The following description is informative – in case of differences the respective norms are valid.

5.2.1 State diagrams

State diagrams are separated into a state diagram for the infrastructure and for the EV in order to run individual state machines. The state diagrams are shown in the Figure 5-3 and Figure 5-4.

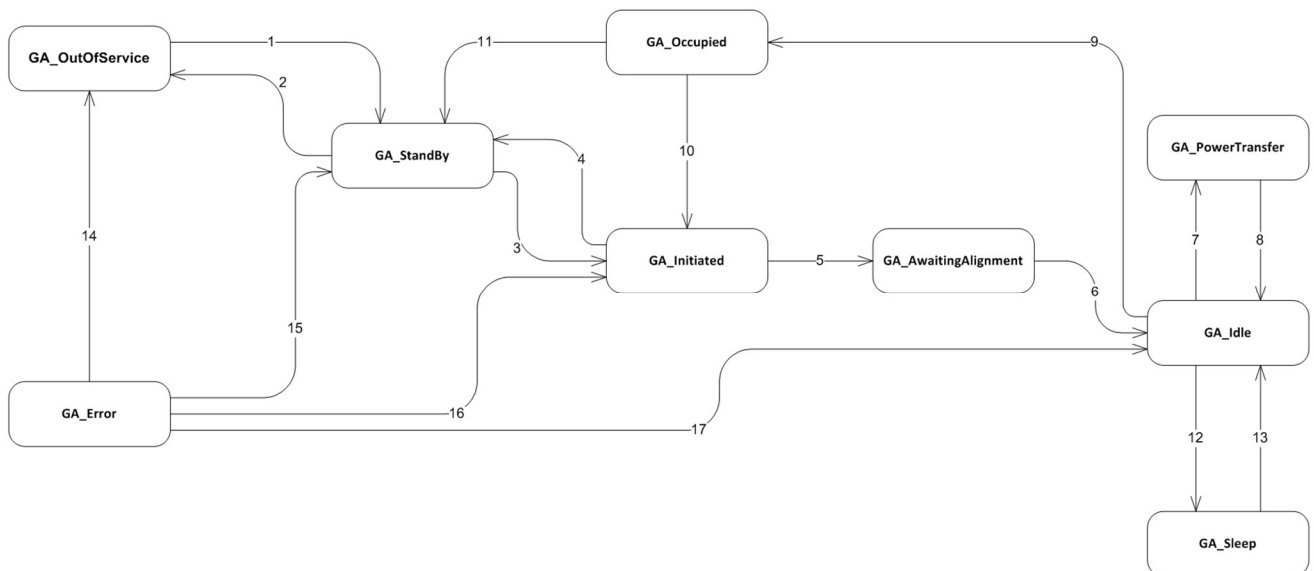

Figure 5-3 Infrastructure state diagram

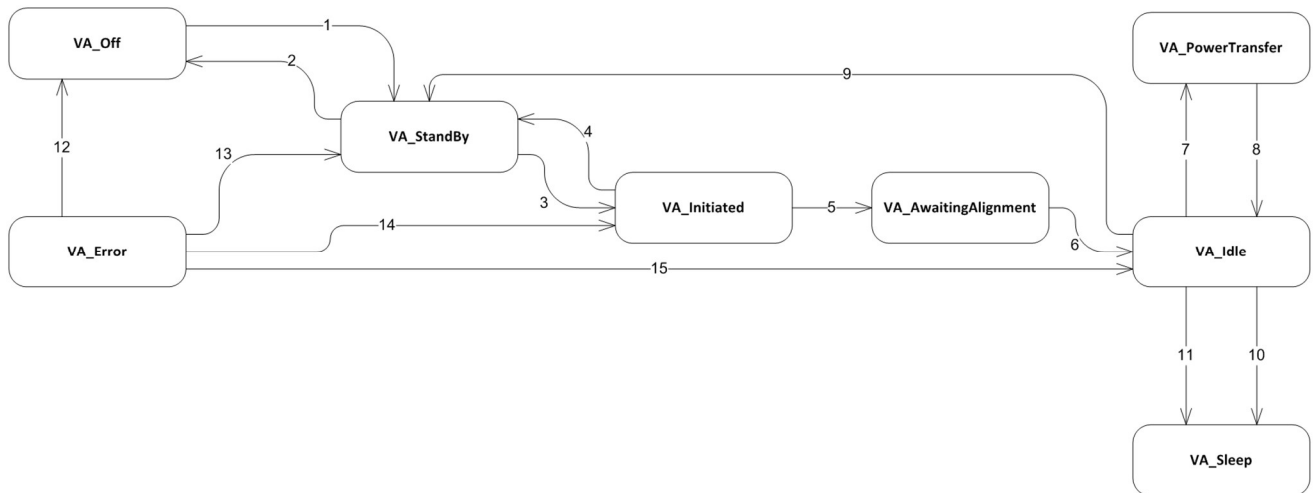

Figure 5-4 EV State diagram

5.2.2 Communication sequence

5.2.2.1 Service selection

Service selection includes communication setup as soon as the EV has identified a WiFi communication for wireless charging (refer to ISO 15118-8 for details). The message exchange according to ISO 15118-2 in relation to the state diagram is shown in Figure 5-5.

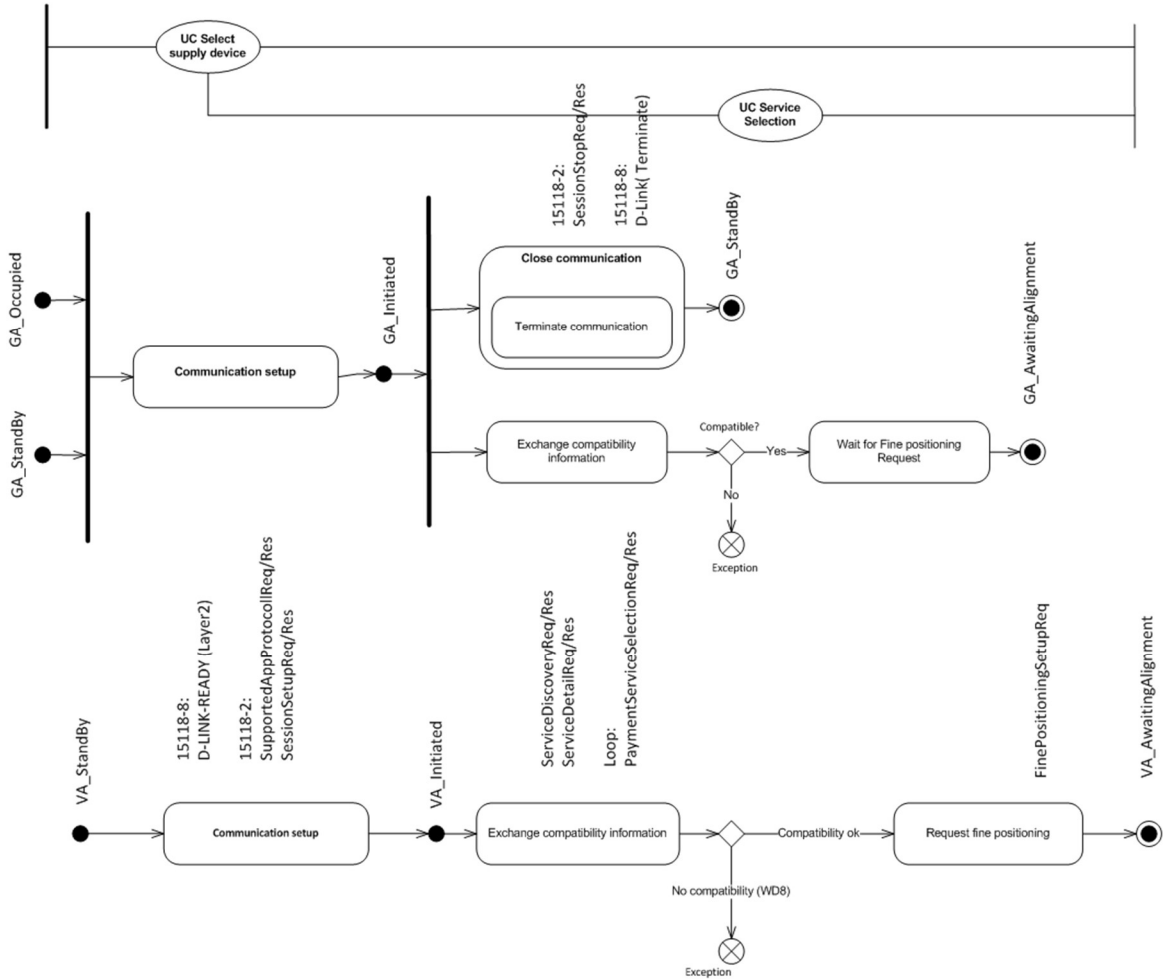

Figure 5-5 Communication sequence for service selection.



For communication setup, the following ISO/IEC 15118-2 Ed.2 messages shall be exchanged between SECC and EVCC:

- SupportedAppProtocolReq/Res;
- SessionSetupReq/Res.

After the successful exchange of SessionSetupReq/Res, the state of the EV is VA_initiated and the state of the supply device is GA_initiated.

After communication setup, the EVCC informs the SECC about the capabilities of the EV. In addition, the SECC shall inform the EVCC about available service capabilities at different supply sites.

In order to determine a method for fine positioning and pairing and initial alignment check, the EVCC shall choose a supported method provided by the SECC. With respect to the methods described in clause 4, the EVCC will choose LF method for fine positioning and SR-Signal as pairing and as alignment check method.

If the hardware or billing method is not compatible then the WPT sequence terminates.

The following message sequence (from ISO/IEC 15118-2 Ed.2 (under consideration)) shall be performed by the SECC and EVCC:

- ServiceDiscoveryReq/Res;
- ServiceDetailReq/Res;
- ServicePaymentSelectionReq/Res;

After the successful exchange of the messages, state of the EV is VA_AwaitingAlignment and the state of the supply device is GA_AwaitingAlignment.

After Service selection, the EV and supply device shall perform Fine positioning. Fine positioning provides support for the EV's secondary device and the primary device to become properly aligned.

For performing the fine positioning, the LF method as described in clause 4 is applied. Necessary information about this method has been exchanged during service selection or will be exchanged with the ISO 15118 messages given below.

The following message sequence from ISO/IEC 15118-2 Ed. 2 shall be performed by the SECC and EVCC:

- FinePositioningSetupReq/Res
- FinePositioningReq/Res;

Note that the message FinePositioningReq/Res may be repeated as needed to achieve proper alignment.



5.2.2.2 Fine Positioning – Pairing - Final Compatibility Check – Alignment check

After successful fine positioning, the EVCC and SECC shall ensure that the primary device and secondary device are uniquely paired. According to the selection being made during service selection the SR-Signal method is applied (see also clause 4.3).

The following message sequence from ISO/IEC 15118-2 Ed. 2 shall be performed by the SECC and EVCC:

- PairingReq/Res;

After successful Pairing, the EVCC and SECC shall ensure that the primary device and secondary device are compatible.

The following message sequence from ISO/IEC 15118-2 Ed. 2 shall be performed by the SECC and EVCC:

- AuthenticationReq/Res
- ChargeParameterDiscoveryReq/Res.

Note that failure of final compatibility check results in an exception that will return the states to GA_Initiated and VA_Initiated.

After successful final compatibility check, the EVCC and SECC shall ensure that the primary device and secondary device are properly aligned.

The following message sequence (from ISO/IEC 15118-2 Ed. 2) shall be performed by the SECC and EVCC:

- AlignmentCheckReq/Res;

EV sends the AlignmentCheckReq message to supply device.

With sending the successful AlignmentCheckRes the supply device state turns into GA_IDLE

With receiving the successful AlignmentCheckRes message the EV status turns into VA_IDLE.

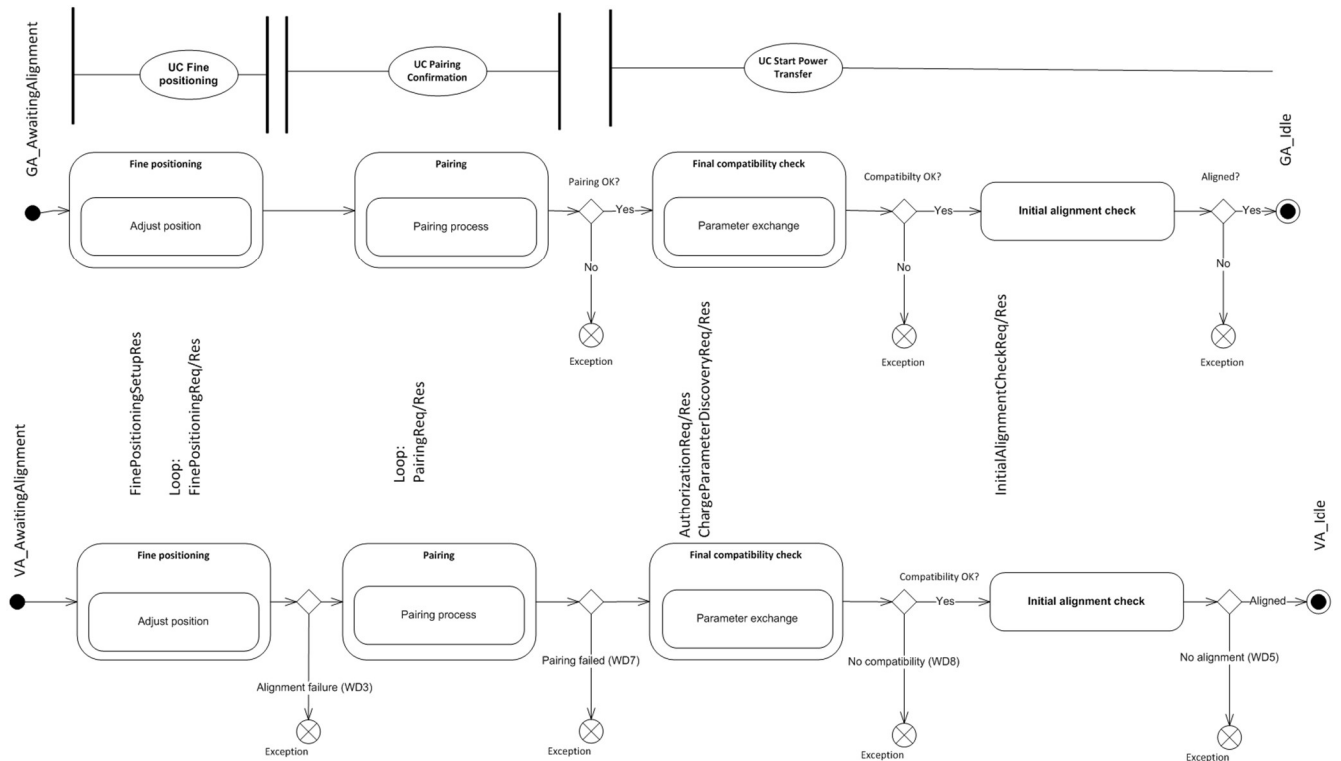

Figure 5-6 Communication sequence for fine positioning, pairing and alignment check

5.2.2.3 Prepare power transfer

In order to transfer power, the EVCC requests the SECC to start power transfer via communication.

The following message sequence from ISO/IEC 15118-2 Ed. 2 shall be performed by the SECC and EVCC:

- PowerDeliveryReq/Res,
- PowerDemandReq/Res.

With sending a PowerDemandReq, the state of the EV turns into VA_PowerTransfer.

Receiving this message, the supply device will start transfer power. With sending a PowerDemandRes confirming the requested value, the state of the supply device turns into GA_PowerTransfer.

With the PowerDeliveryReq the EVCC informs the SECC that the SR-Signal is used as clearance signal and is turned on as long as the EVCC is able to receive power. With this information, the supply device can use this signal for continuous alignment check during power transfer and react properly when detection of the SR Signal is not given.

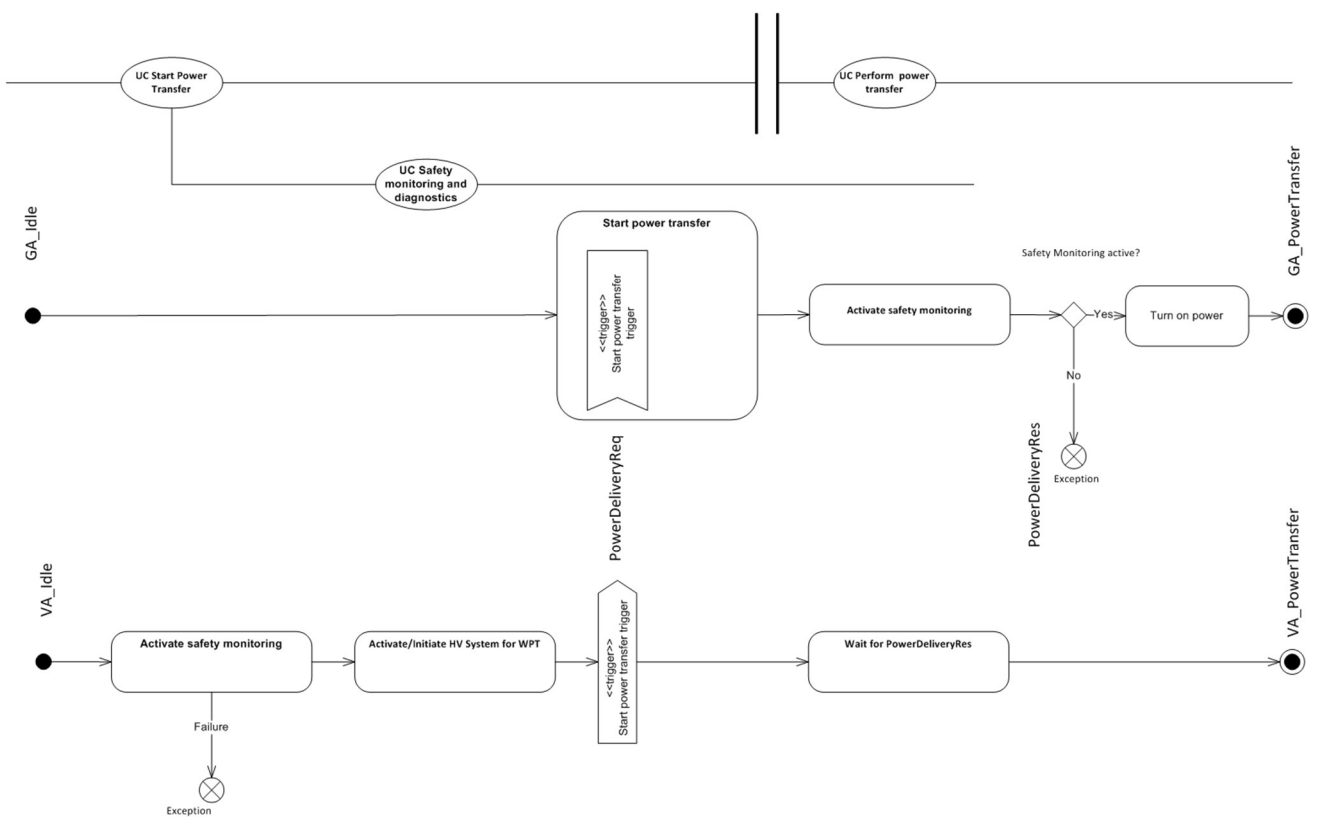

Figure 5-7 Prepare power transfer



5.2.2.4 Perform power transfer

After successful start power transfer, the EVCC requests changes to the power being transferred via communication.

The following message sequence from ISO/IEC 15118-2 Ed. 2 shall be performed by the SECC and EVCC:

- PowerDemandReq/Res.

By continuously repeating the power demand messages, the power transfer can be controlled and communication reliability checked. The supply device may change the transmittable power limit at any time. The EV may request different power levels at any time.

PowerDemandReq/Res is used not only for controlling power being transferred, but also with exchanging amount of power transmitted and received.

The SECC shall indicate to the EVCC how much power is being transmitted. The EVCC shall indicate to the SECC how much power was received. The supply device shall check the alignment continuously during wireless power transfer. The EV may check the alignment continuously during wireless power transfer.

When the EVCC does not want power being transferred, the EVCC requests power to be set to zero, and then requests stop power transfer via communication.

The following message sequence from ISO/IEC 15118-2 Ed. 2 shall be performed by the SECC and EVCC:

- PowerDemandReq/Res;
- PowerDeliveryReq/Res.

The termination of power transfer is requested by the EV by sending a PowerDeliveryReq with the flag "ChargeProgress" set to "Stop".

After power ramp down has been finished, the termination of power transfer shall be confirmed by the SECC by sending the PowerDeliveryRes. The state of the supply device turns into GA_Idle.

After reception of the successful PowerDeliveryRes, the state of the EV turns into VA_Idle.

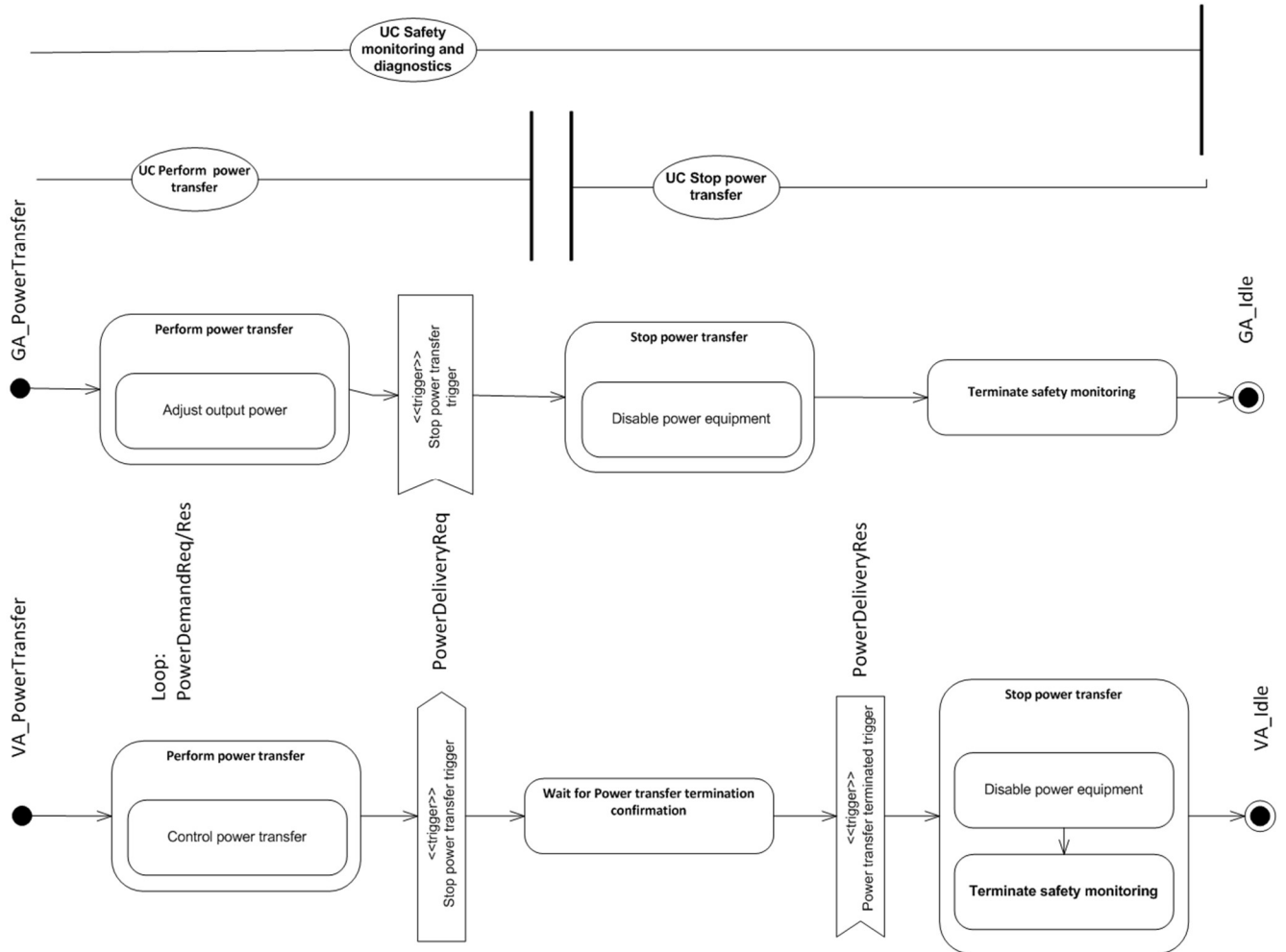

Figure 5-8 Perform power transfer – stop power transfer

5.2.2.5 Terminate power transfer

When the EVCC no longer wishes to maintain the session with the SECC, the EVCC requests the session to terminate via communication.

The following message sequence from ISO/IEC 15118-2 Ed. 2 shall be performed by the SECC and EVCC:

- SessionStopReq/Res.

After terminate communication, state of the EV is VA_StandBy and the state of the supply device is GA_Occupied.

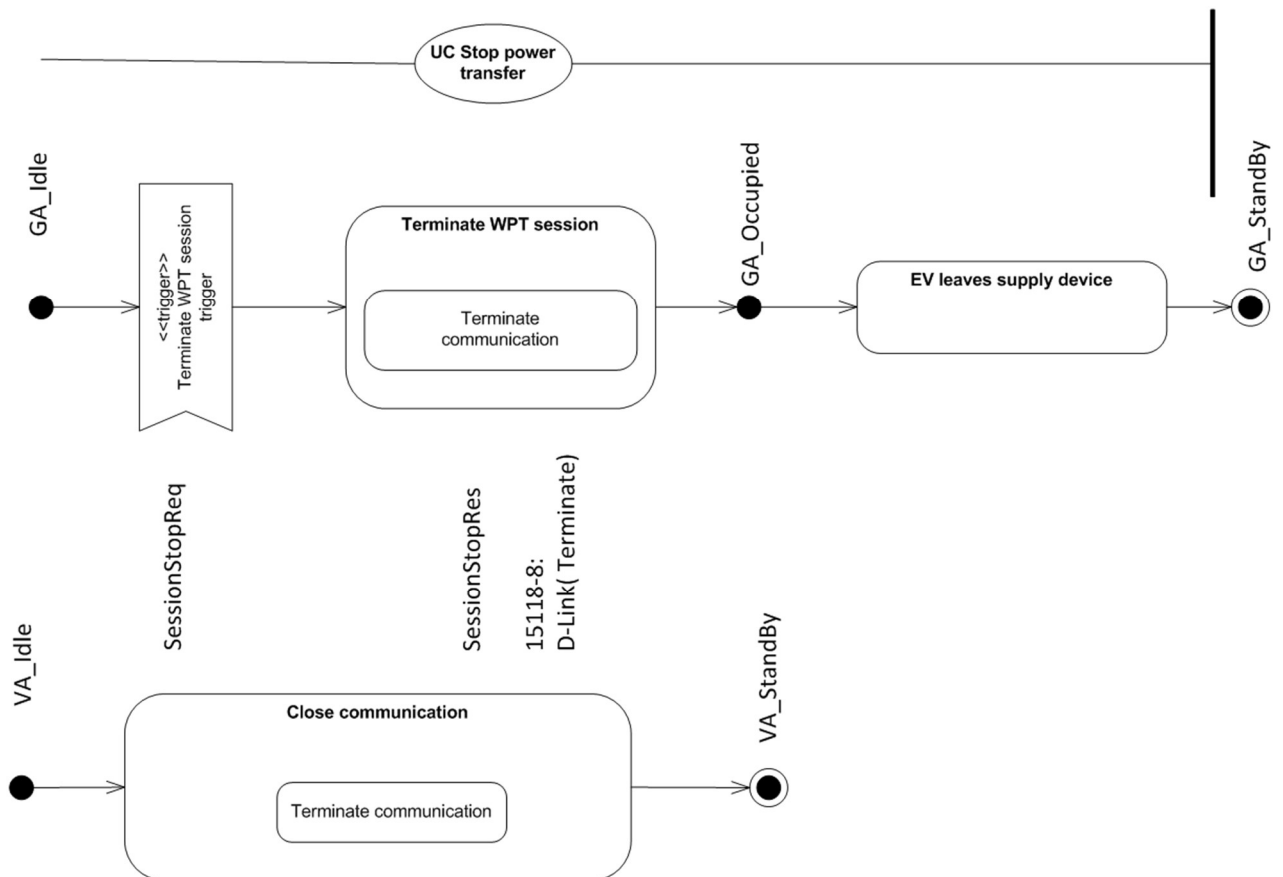

Figure 5-9 Terminate charging session

5.2.2.6 Power Saver / wakeup:

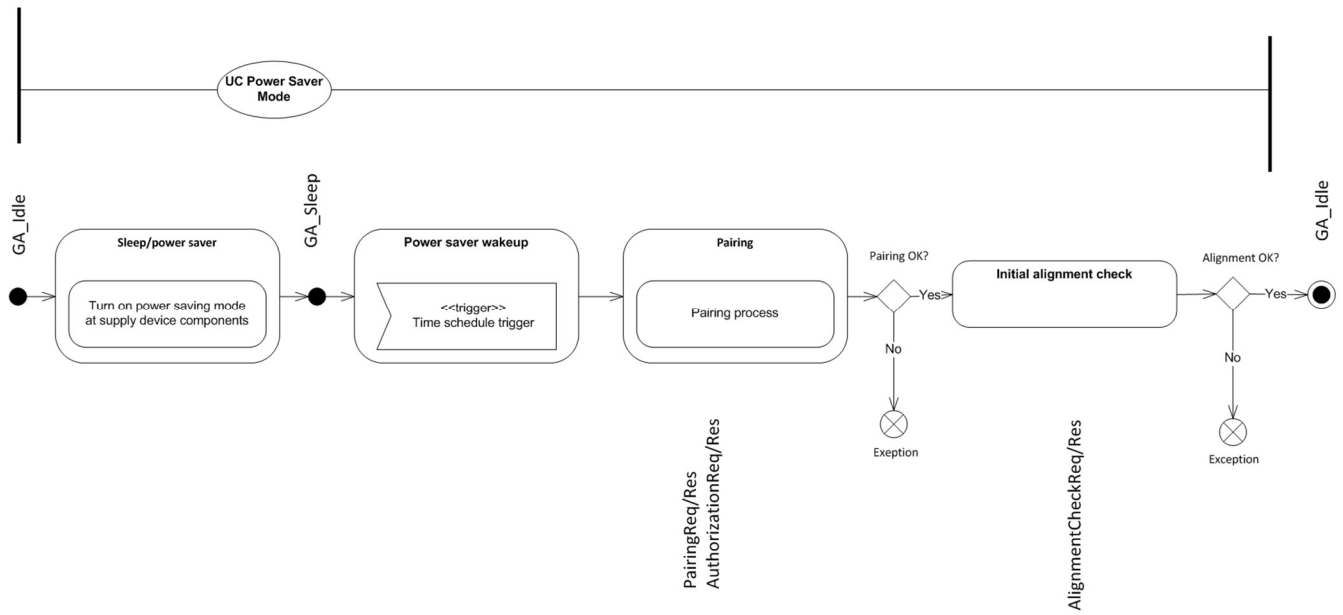

Figure 5-10 Power saver / wake up



5.3 Power transfer control

5.3.1 General description

Power transfer control shall be based on the messages and timings defined in ISO 15118-2, SAE J2954 RP and IEC 61980-2 DTS.

Additionally, the CharIN E.V. recommends to apply the following requirements.

In order to allow safe and stable power transfer from GA to VA both systems incorporate a splitted control loop. The VA transmits the target power and the measured input power to the GA, while the GA calculates the control error and controls the system output.

For a greater freedom in system design, different degrees in complexity are allowed for a VA. It is distinguished between a basic VA and a smart VA. The difference will be clarified in the description of the control loop.

The automatic power control is separated in stages which require different parameter sets to be exchanged:

- setup
- ramp-up
- steady-state
- ramp-down
- power-off

5.3.2 Basic system requirements

In order to set up the control loop, both systems exchange initial parameters according to ISO 15118-2 during the setup phase. These parameters determine which influence both systems may have on each other.

The following table states which control mechanisms in a WPT systems are optional and mandatory. The according information shall be exchanged during the setup phase.

Table 4 optional and mandatory control mechanisms for GA and VA



control mechanism	GA	VA
power control via primary coil current	mandatory	-
frequency (GA: capability, VA: compatibility)	mandatory	.
adjustable impedance matching	-	optional
Adjustable load resistance	-	optional
emergency shutdown	mandatory	mandatory

5.3.3 Control loop

5.3.3.1 Basic VA

A basic VA comprises no inherent control mechanism and its only way to control the WPT is to send a power demand and the measured DC charging power. It is the GAs task to calculate the control error and correct the power output accordingly without exceeding the given limits. This represents the master control loop. Its output signal is a power demand for the GA power stage. The slave control loop acts exclusively inside the GA and controls the power stage according to the power demand of the master control loop.

The available time slot for measuring, communicating and processing is defined as response time EV and response time EVSE. To ensure stable operation, the respective signals for the master power control loop shall be sent with this response time.

An explanation of the response times is given in the following figure. Values are defined in the chapter "Control system parameter".

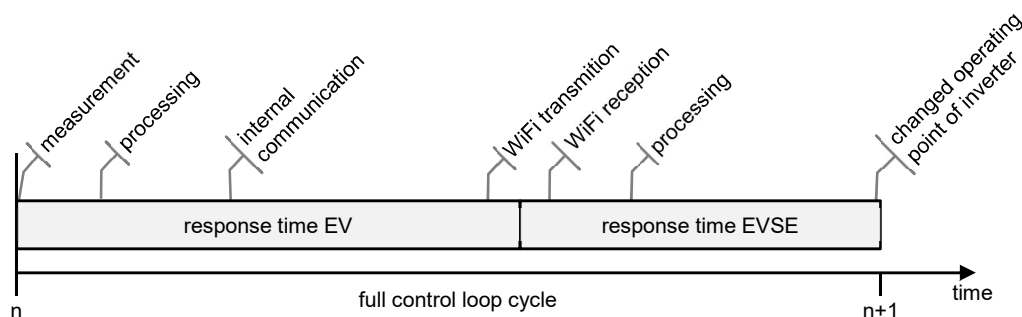

<<figure: control loop cycle with response times>>

After a setpoint step change the master control loop shall achieve a control error of less than +5 / - 10% of P_{req} within one complete control loop cycle after receiving the signal EVInputPower. Two

complete control loop cycles after a step change the WPT power level shall be stabilized with a maximum deviation of $\pm 3\%$ of P_{req} .

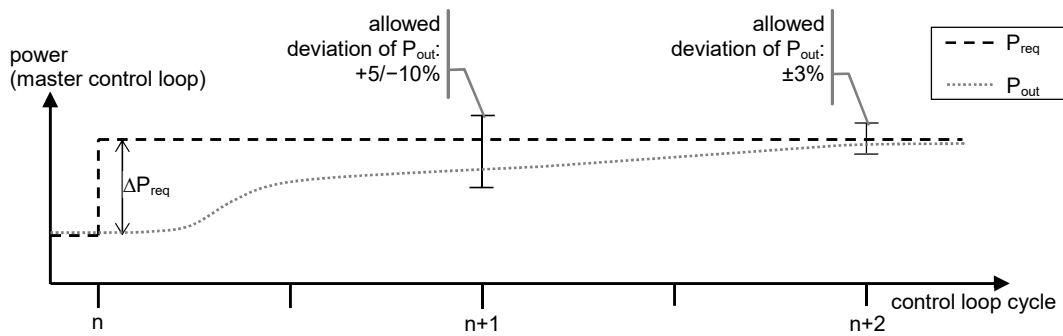

<<figure: deviation of power demand and output>>

A GA shall be able to use frequency tuning in order to optimize overall system efficiency and to drive a basic VA without any tuning mechanisms.

The required parameter and messages for power control are to be applied as described in ISO 15118.

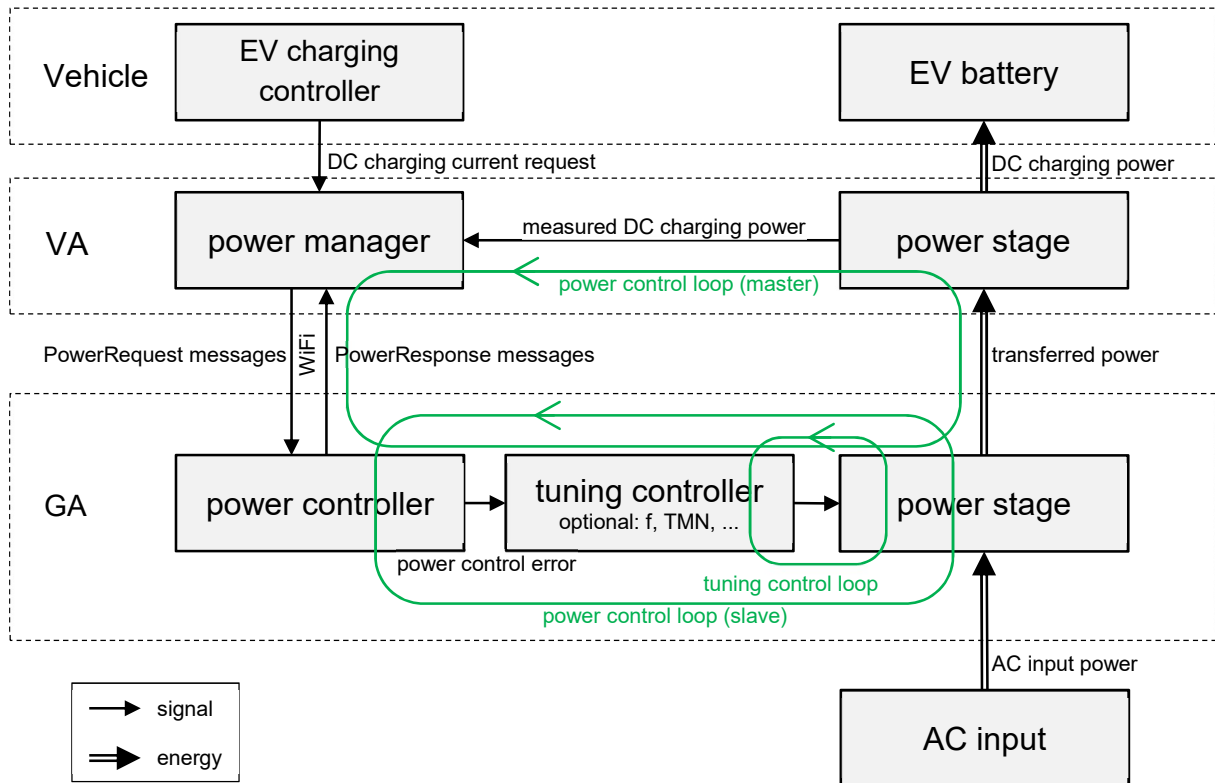

Figure 5-11 control loop basic VA

5.3.3.2 Smart VA

In contrast, a smart VA can control certain parameters as input impedance and/or resonance compensation with regard to system efficiency and performance. As a first take, both sides optimize the power transfer towards their own optimal operating point.

During power transfer, each system may request parameter changes from the opposing side in order to optimize its operating point. These shall be produced if they do not exceed systemic restrictions or contradict a systems own optimization goals.

During any tuning operation, the primary power controller shall be active in order to prevent any system overload.

A thermally oriented optimization and control is possible by decreasing the requested (VA) or delivered (GA) power according to actual thermal conditions. Controlling the counterpart's temperature is not foreseen at this point.

Additionally to the standardized message set, a designer may include vendor specific messages in order to further optimize a matched system. These proprietary messages may be ignored by any system not understanding the content. Proprietary messages must include a vendor specific unique ID in order to prevent misinterpretation.

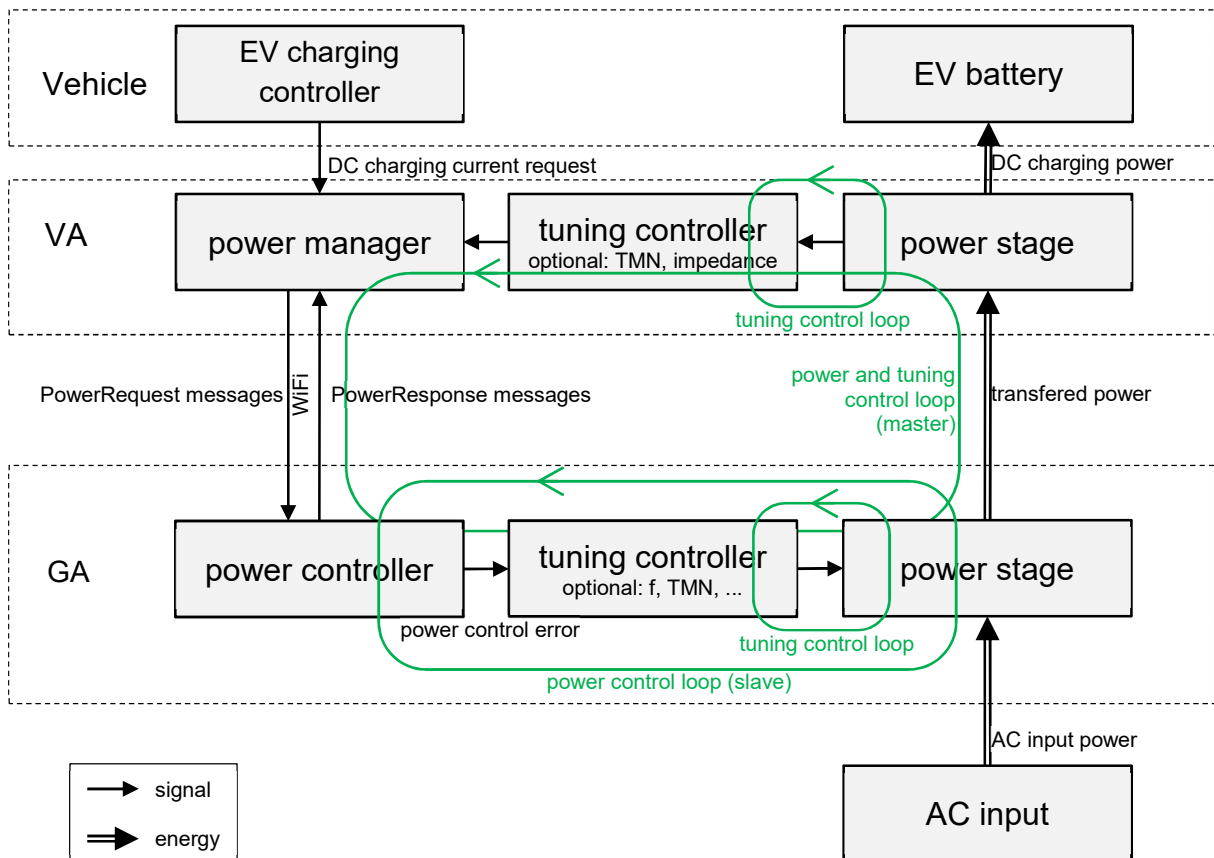

Figure 5-12 control loop smart VA

5.3.5 Control system parameter

Table 5 requirements for the output response performance of the EVSE

Item	Symbol	Minimum	Nominal	Maximum	unit
power output range	P_{out}	0	-	maximum power the GA is able to transmit	W
Power resolution	P_{out}	0,1	-	50	W
power request range	P_{req}	500	-	maximum common power of GA and VA	W
maximum slew rate of power request	ΔP_{req}	-2k	-	10% of $P_{req,max}$	W/s
maximum slew rate of power output	ΔP_{out}	-2k	-	10% of $P_{out,max}$	W/s
response time EV	$t_{d,VA}$	-	-	650	ms
response time EVSE	$t_{d,GA}$	-	-	350	ms

The allowed maximum response time includes on EV side the measurement, calculation, internal communication, transmission by WiFi. On EVSE side, the response time includes receiving data by WiFi, internal communication and processing, changing operating point of power electronics.

The GA should be able to apply the full range of the slew rate of power output.

The entire system needs to decrease power or switch itself off if the required overall efficiency cannot be met for 30 s. This dwell time shall prevent unwanted shutdown events during a slow ramp up phase.

A controlled shutdown should be done by applying the given slew rate to ramp down the power request.

In case of a GA based emergency shutdown due to object detection or other reasons, the output power shall be reduced to zero within 200 ms after the respective event. In case of a vehicle based forced shutdown event the VA shall be able to safely switch off power transfer independently from the GA.

The GA shall be informed by the respective communication interface within 200 ms and switch off within 500 ms after the shutdown event.



Additionally, the GA shall be able to recognize a sudden shutdown event of the VA by monitoring the power stage and react accordingly by disabling its own power output within 10 ms. This event shall not cause any permanent damage on either side of the WPT system.

The counterpart must be informed of the shutdown situation.

In a load dump event (e.g. battery disconnects) both sides VA and GA shall be able to safely switch off independently and inform the counterpart.

The VA controller and electronics must draw its low voltage power from a vehicle based power source. It must not be powered by the GA.

5.3.6 Conformance tests

The general functionality of power control and tuning as well as the compliance with control system parameters will be verified during the electrical interoperability test on a test stand.



6 Safety

6.1 Safety concept

In order to ensure a safe power transfer, the following safety interface has to be ensured. The implementation of this safety requirements is the decision of the manufacturer. Deriving req. from safety requirement:

Infrastructure safety requirements:

- The power as requested by EV shall not be exceeded within the tolerance range.
- FOD – Foreign Object Detection
- LOP – Living Object Protection



6.2 LOP/EMF

ICNIRP 2010 should apply.

The GA is fully responsible for the functionality of living object protection.

Requirements to LOP system:

- Areas and test procedure according to SAE J2954 RP (2017-11-27)
- Additionally, the full area under the car shall be either
 - detect LOP and disable WPT or reduce magnetic field accordingly
 - stay under ICNIRP 2010 level

6.3 FOD

The GA is fully responsible for the functionality of foreign object detection.

For all test objects which are listed in SAE J2954 recommended practice, it must be shown that no thermal event will occur according to SAE J2954 RP test procedure.



7 EMC

EMC testing has to be performed according to CISPR11.

8 GA location

For interoperability, the location of the GA should be at the same position on the ground to ensure that all manufactures have a possibility to charge on semi-public and public infrastructure.

The test stand point of the GA is located at the coil center. This entails that the coil position in the EVs is also affected.

General topics:

- Inductive charging cannot solve the issue that currently most vehicles do not fit on 5m parking spaces (EU, Japan, Singapore etc.)
- From a customer point of view, a front coil positioning is best in terms of maneuverability, independent of automatic or manual driving/parking
- Support for backward and forward parking is needed from customer perspective for 90° parking
- By applying a natural offset position for DD systems, all matched and unmatched systems can be used within a single parking position.

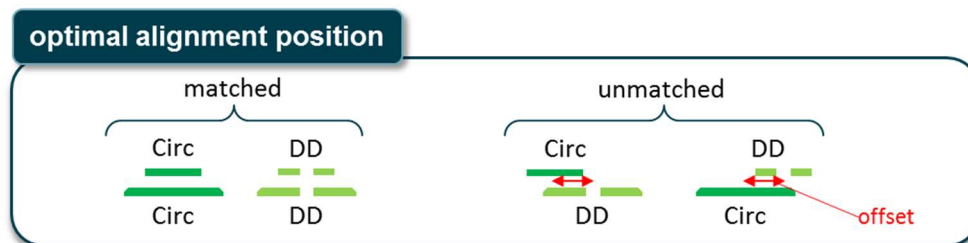

The parking spaces are divided in two cases:

1. Perpendicular Reverse Parking

Perpendicular Forward, Angle Forward and Parallel Parking Each case is described in the following sub item.

8.1 Perpendicular Reverse Parking

Backward parking is the most popular parking behavior in Asia. For this case, the vehicle length is more important and it is possible that longer vehicles could not charge if an obstacle (e.g. a wall) limits the parking space. Because of that limitation, the parking space should be at least 5,5m.

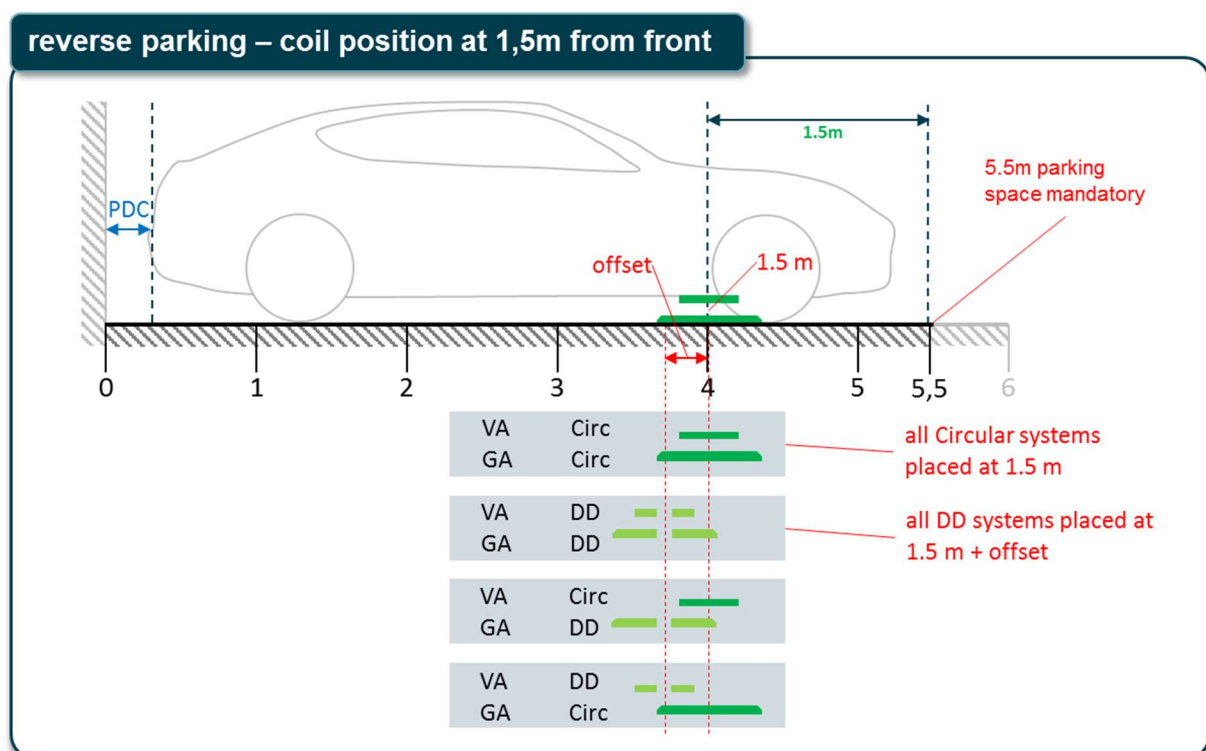

8.2 Perpendicular Forward, Angle Forward and Parallel Parking

In case of forward parking, a minimal length of 5m for the parking space is needed.

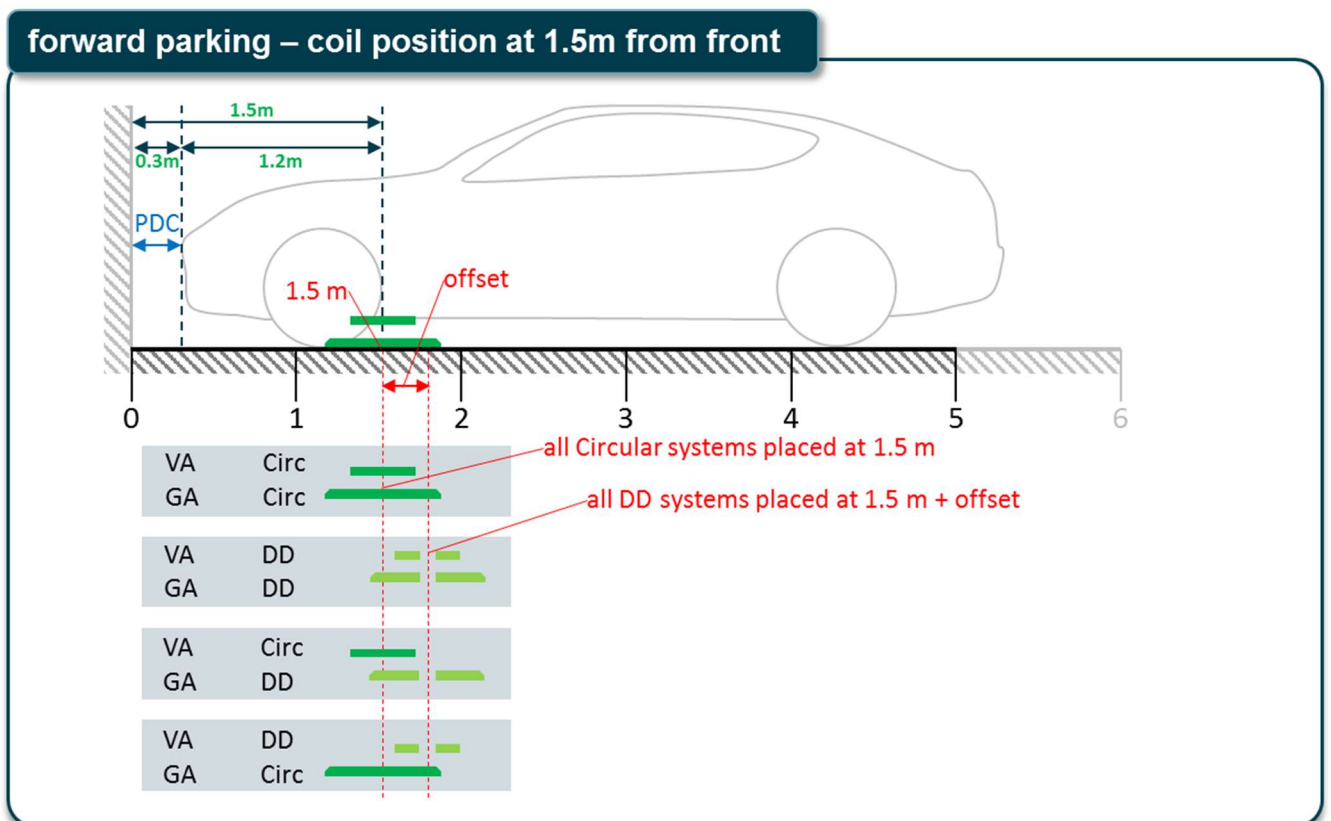



9 Diagnosis

A product GA shall be able to provide basic diagnosis data to a VA in order to recognize reoccurring events such as under coupling or failure of the positioning system.

For a better evaluation of the diagnostic results, the GA shall determine whether it is a privately or (semi-) public owned device.

A privately owned device is intendedly only used by known EVs. Thus, extended diagnostic data may be provided to a VA in order to allow deeper analyses of GA based faults as these concern the EV owner directly. These data may be vendor specific.

A (semi-) public used GA will only provide information directly related to the charging event.

The following information shall be provided by a public EVSE:

EVDiagnosisRequest

- EV requests information about relevant events during current charging session.

EVSEDiagnosisResponse

- communication failure
 - Informs the EV that WiFi communication between GA and VA failed.
 - Signal shall include time stamp of first event and event counter.
 - Only to be sent if communication can be re-established.
- unexpected power loss
 - Informs the EV that the EVSE is not able to draw the required power from AC grid.
 - Signal shall include time stamp of first event, event counter, flag for permanent or temporary condition.
- poor operating point
 - Informs the EV that no operating point could be found that allows to transfer the requested power. This could be because of over or under coupling.
 - Signal shall be sent only while “poor operating point” is active.



10 Conclusion & Next Steps

This position paper was created to support the industry to develop the next generation of inductive charging systems. In the future, further developments and definitions in standardization are expected and will be followed by the industry.

11 Abbreviations

Abbreviation	
AC	Alternating Current
DC	Direct Current
CCS	Combined Charging System
BEV	Battery Electric Vehicle
PHEV	Plug-In Hybrid Electric Vehicle
EV	Electric Vehicle
GA	Ground Assembly
VA	Vehicle Assembly
EMC	Electro Magnetic Compatibility
EMF	Electromagnetic Force
EVSE	Electric Vehicle Supply Equipment
OEM	Original Equipment Manufacturer
WPT	Wireless Power Transfer
MF	Magnetic flux
U	Voltage
PCB	Printed circuit board
SECC	Supply Equipment Communication Controller
EVCC	Electric Vehicle Communication Controller
CC/DD	Circular /DD - coil
DUT	Device Under Test
LF	Low Frequency
SR-Signal	Short Range Signal
VLF	Very Low Frequencies



ITU	International Telecommunication Union
WLN	Wireless Local Area Network
LPE	Low Power Excitation
P	Power
t	time
FOD	Foreign Object Detection
LOP	Living Object Protection
RFID	Radio Frequency Identification



Reference

SAEJ2954 Recommended Practice (2017-11-27)

Authors

This document was created by the following persons on behalf of the CharIN association:

Matthias Hardt

Dirk Herke

Erik Herkenrath

Dr. Susanne Koblitz

Dr. Nico Kreuzer

Steffen Kümmel

Angelika Spörer

Contact

CharIN e. V.

Charging Interface Initiative

Coordination Office

c/o innos – Sperlich GmbH

Schiffbauerdamm 12

10117 Berlin

Phone: +49.30.288 8388-0

Fax: +49.30.288 8388-19

E-Mail: coordination@CharINev.org

Web: www.CharINev.org