

CharIN Umbrella Document for Charging System Basic DC EVSE

of Charging Interface Initiative e.V.

Date of last change (2025-12-05)

Charging Interface
Initiative (CharIN) e.V.
EUREF-Campus 10-11
10829 Berlin Germany

Contact

André Kaufung
Phone +49 30 288 8388-0
Fax +49 30 288 8388-19
Mail coordination@charin.global
Web www.charin.global

Contents

1.	Introduction	4
2.	Requirements for Test System HW and SW	8
3.	Conformance Test for DC Charging System Basic EVSE	9
3.1.	Conformance Test Revisioning.....	9
3.1.1.	CharIN internal numbering of Test Case documents	9
3.1.2.	CharIN Conformance Test Label.....	11
3.1.3.	Guideline for test verdict to obtain robust test results.....	11
3.1.4.	Guideline for power flow configuration of communication test.....	12
3.2.	Conformance Test for DC Charging System Basic EVSEs.....	13
3.2.1.	DIN SPEC 70122:2018 DC EVSE Basic Test cases.....	14
3.2.2.	“Test Cases for DIN SPEC 70121:2014 Implementation Guide” DC EVSE Basic Test cases	23
3.2.3.	IEC 61851-1 DC Charging System Basic EVSE Test cases	33
3.2.4.	IEC 61851-23 DC Charging System Basic EVSE Test Cases.....	34
3.2.5.	IEC 61851-21-2 DC Charging System Basic EVSE Test Cases (EMC).....	37
3.2.6.	IEC 62196 Vehicle Coupler Test Cases	37
3.3.	Requirements for Test Systems (CCTS).....	38
3.4.	Requirements for Testing houses	38
4.	Reference	39

Abbreviations

AC	Alternating current
BS	Basic Signaling
CCS	Combined Charging System
CCTS	CCS Conformance Test System
CP	Control Pilot
DC	Direct current
DIN	German Institute for Standardization
ECU	Electronic Control Unit
Ed	Edition
EIM	External Identification Means (External payment)
EV	Electric Vehicle
EVSE	Electric Vehicle Supply Equipment
FC	Fast Charging
HLC	High Level Communication
HPC	High Power Charging
IC-CPD	In-Cable Control and Protection Device
IEC	International Electrotechnical Commission
ISO	International Organization for Standardization
OEM	Original Equipment Manufacturer, here automotive manufacturers
PE	Protective Earth
PICS	Protocol Implementation Conformance Statement
PIXIT	Protocol Implementation Extra Information for Testing
PLC	Power Line Communication
PnC	Plug and Charge
PP	Proximity Pilot
PWM	Pulse Width Modulation
QAP	Quality Assurance Plan
RFID	Radio Frequency Identification
SAE	Society of Automotive Engineers
SECC	Supply Equipment Communication Controller
SUT	System under Test
US	United States of America

1. Introduction

1.1. General

The Combined Charging System (CCS) is based on open and universal standards for EVs and EVSEs. CharIN is promoting the CCS as an internationally competitive system for DC and AC charging. To ensure reliable, safe and robust charging with the CCS, CharIN has taken action to close gaps in existing charging standards by providing implementation guides, and, where considered necessary, to specify conformance and interoperability Test Cases for electric vehicles (EV) and electric vehicle supply equipment (EVSE) that implement CCS. In addition, CharIN provides a hardware specification for Test Systems and is developing a qualification process for a CharIN CCS Test System (CCTS) that tests conformance of the charging behavior of an EV or an EVSE at the charging interface with the requirements in existing standards and in related CharIN guides.

In a first step, CharIN is providing system implementation guides as well as testing guides related to the charging functions of Charging System Basic and to the CCS charging technology manual conductive charging¹. Within this step, the first focus is testing of DC Charging System Basic EVSE.

¹ Refer to the CharIN Implementation Guide to Charging System Basic, provided by the CharIN coordination office.

1.2. Purpose and scope of this document

The current document provides a guideline for conformance testing of the charging functions of DC Charging System Basic EVSE that are used for manual conductive charging.

The following standards contain relevant system requirements and therewith constitute the implementation baseline for DC Charging System Basic EVSE, as recommended by CharIN:

INTERNATIONALLY valid documents		ADDITIONAL documents that are ONLY relevant for individual MARKETS										Documents		
Combo 1 Type 1	Combo 2 Type 2	EU	US	DE	CA	AU	KR	SG	IN	CCS Bas. V1 Doc.No.	Document Name	Edition/year	Short description	
n.a.	n.a.	X								1	EN 17186	Ed.1	Electricity fuel labelling	
n.a.	n.a.	X								2	EN 50620	2017	Charging cables for EVs	
X	X									3	DIN SPEC 70121	2014	DC PLC	
X	X									4	IEC 60364-7-722	Ed.2	AC/DC, local installation	
X	X									5	IEC 61851-1	Ed.3	general requirements conductive charging, CP, PP [Annex B], PWM, AC sequences [Annex A]	
X	X									7	IEC 61851-21-2	Ed.1	Off-board charger EMC	
X	X									8	IEC 61851-23	Ed.1	DC safety, sequences, power transfer [System C]	
X	X									9	IEC 61851-23	Ed.1 Cor.1	DC safety, sequences, power transfer [System C]	
n.a.	n.a.			X						10	DIN EN 61851-23 Berichtigung 2 (VDE 0122-2-3 Berichtigung 2)	2018	DC electrical safety related to DIN EN 61851-23 (VDE 0122-2-3):2014-11	
X	X									11	IEC 61851-24	Ed.1	DC digital communication [System C]	
X	X									12	IEC 61851-24	Ed.1 Cor.1	DC digital communication [System C]	
X	X									13	IEC 62196-1	Ed.3	AC/DC plugs, couplers general [Type 1 & 2 basic interface, Configuration EE & FF combined interface]	
X	X									15	IEC 62196-3	Ed.1	DC Combo 1/2 plugs couplers [Configuration EE & FF combined interface] (max d.c. current 200A)	
X	X									18	IEC 62893-1	Ed.1	AC/DC charging cable general	
X	X									22	ISO Important Information related to IEC 61851-23:2014 and ISO 17409:2015	2017	Information on requirements related to the safety objective "protection against electric shock"	
n.a.	n.a.		X							23	SAE J1772	2017	AC/DC, PWM, Type 1, Combo 1	
n.a.	n.a.		X							24	SAE J2953/1	2013	AC/DC (IOP CP + Prox)	
n.a.	n.a.		X							25	UL 2202	Ed.2	EVSE general	
n.a.	n.a.		X							26	UL 2231-1	Ed.2	Protection systems for EVSE	
n.a.	n.a.		X							27	UL 2231-2	Ed.2	Protection devices for EVSE	
n.a.	n.a.		X							28	UL 2251	Ed.4	EV plugs, couplers	
n.a.	n.a.		X							30	UL 62	Ed.20	Flexible cords and cables	

Table 1. List of standards that constitute the implementation baseline for DC Charging System Basic EVSE. For documents highlighted in green, CharIN is providing implementation guidelines (see below).

The following standards contain Test Case specifications related to the implementation baseline for DC Charging System Basic EVSE:

INTERNATIONALLY valid documents		ADDITIONAL documents that are ONLY relevant for individual MARKETS										Documents			
Combo 1 Type 1	Combo 2 Type 2	EU	US	DE	CA	AU	KR	SG	IN	CCS Bas. V1 Doc No.	Document Name	Edition/year	Short description		
n.a.	n.a.	X								2	EN 50620	2017	Charging cables for EVs		
X	X									31	DIN SPEC 70122	2018	DC PLC		
X	X									4	IEC 60364-7-722	Ed.2	AC/DC, local installation		
X	X									5	IEC 61851-1	Ed.3	general requirements conductive charging, CP, PP [Annex B], PWM, AC sequences [Annex A]		
X	X									7	IEC 61851-21-2	Ed.1	Off-board charger EMC		
X	X									32	DIN VDE V 0122-2-300	2016	DC sequences, power transfer [System C]		
X	X									13	IEC 62196-1	Ed.3	AC/DC plugs, couplers general [Type 1 & 2 basic interface, Configuration EE & FF combined interface]		
X	X									15	IEC 62196-3	Ed.1	DC Combo 1/2 plugs couplers [Configuration EE & FF combined interface] (max d.c. current 200A)		
X	X									18	IEC 62893-1	Ed.1	AC/DC charging cable general		
n.a.	n.a.	X								23	SAE J1772	2017	AC/DC, PWM, Type 1, Combo 1		
n.a.	n.a.	X								34	SAE J2953/2	2014	AC/DC (IOP CP + Prox) test procedures		
n.a.	n.a.	X								25	UL 2202	Ed.2	EVSE general		
n.a.	n.a.	X								26	UL 2231-1	Ed.2	Protection systems for EVSE		
n.a.	n.a.	X								27	UL 2231-2	Ed.2	Protection devices for EVSE		
n.a.	n.a.	X								28	UL 2251	Ed.4	EV plugs, couplers		
n.a.	n.a.	X								30	UL 62	Ed.20	Flexible cords and cables		

Table 2. List of standards that contain Test Case specifications related to the implementation baseline for DC Charging System Basic EVSE. For the documents highlighted in green, CharIN is providing additional Test Case specifications, or Test Case specifications that substitute the existing ones (see below).

In the current edition of this guideline, the following charging functions of a DC Charging System Basic EVSE are in focus (according documents are highlighted in grey above):

- proximity detection (PP) according to IEC 61851-1 Ed.3 and IEC 61851-23 Ed.1 (system C)
- basic signaling (BS) using pulse width modulation (PWM) on the control pilot (CP) line according to IEC 61851-1 Ed.3
- power line communication (PLC) according to the DIN SPEC 70121:2014
- DC power transfer sequences and performance of power transfer according to IEC 61851-23 Ed.3 (system C)

In addition to these standards, CharIN has drafted the following implementation guides:

- CharIN “Implementation Guide to DIN SPEC 70121:2014”
- CharIN “IEC 61851-23:2014 – Implementation guide for system C”
- CharIN “DC CCS Power Classes V6, 2018-06-24”

Test Cases for DC Charging System Basic EVSE are defined in the following documents:

- DIN SPEC 70122 Ed1:2018 Communication Test Cases
- IEC 61851-1 Ed.3, Annex A.4
- DIN VDE V 0122-2-300:2016-04 Conformance Test Specification IEC 61851-23, Annex CC

In addition, CharIN has drafted the following Test Case documents:

- CharIN Test Cases for DIN SPEC 70121:2014 Implementation Guide
- CharIN EVSE Test Cases for DC charging with system C according to IEC 61851-1 and IEC 61851-23

The Test Case specifications referenced herein focus on the interoperability between EVs and EVSEs at the charging interface as well as the safety and reliability of the charging process. Furthermore, Test Cases related to the performance of the EVSE are provided (referring to the CharIN CCS DC Power Classes). Regarding EMC requirements, one Test Case is referenced that shall be fulfilled.

Conformance testing related to other EMC requirements or the charging cable of a DC Charging System Basic EVSE are out of scope of the current edition. Robustness and interoperability tests of CCS vehicle connectors and inlets are under consideration.

All herein referenced Test Cases (besides the EMC Test Case) are meant to be performed with a test system, such as the CCTS, which emulates the charging behavior of an EV at the charging interface and that can be used for (partially) automatized tests.

The addressees of this guide are manufacturers of such test systems and of DC CCS charging stations.

1.3. Validity of this document

Considerable effort is undertaken to transfer the changes to requirements that are proposed in the CharIN guides, as well as the CharIN Test Case specifications into the next editions of the respective standards. If documents referenced herein are substituted by new editions, a new edition of this guide may be provided, if required.

2. Requirements for Test System HW and SW

The following figure gives an example for a test system architecture.

In principle it can be divided into the Communication part and the power part.

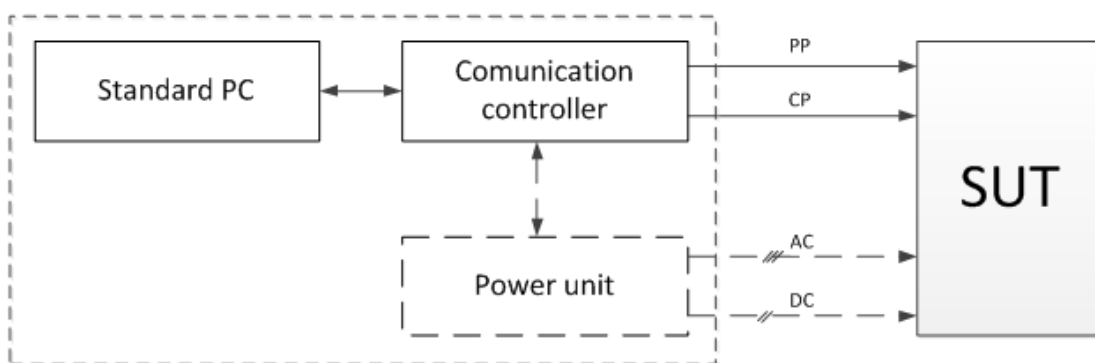

Figure 2 – Test System Architecture

The Test System used for DC Charging System EVSE Basic Conformance Testing must fulfill the requirements for DC EVSE tests given in the CharIN Function Set List in the “CharIN CCTS Specification V0.4.0”.

This document is provided and maintained by CharIN Conformance Test Group vendor team and can be found on the CharIN SVN Server.

3. Conformance Test for DC Charging System Basic EVSE

Conformance Tests for DC Charging System Basic EVSE can be done on

- System level with EVSE and power flow (no ECU only test)

CharIN is the core authority of the certification system for Testing houses and Test Systems to prove capability for DC Charging System EVSE Basic Conformance Testing. The main role of CharIN is to control, monitor, and surveil all entities, namely testing house and CCTS vendor, in the certification system.

CharIN provides labels like “DC Charging System EVSE Basic accredited Testing house” or “DC Charging System EVSE Basic accredited Conformance Test System”.

3.1. Conformance Test Revisioning

Conformance Tests for DC Charging System Basic EVSE will evolve over time. New Test Cases might be added. Others might be changed or deleted. To keep track on type of tests over time a revisioning system/history is applied for CharIN DC Charging System Basic EVSE Tests.

3.1.1. CharIN internal numbering of Test Case documents

The following documents apply for the CharIN Conformance Test DC Charging System Basic EVSE. The document versions/revisions might rise over time.

Document Number	Version as of 26.07.2021	Date of Document	Type of document	Document
#1	1.0.0	2014	Requirements Comm	DIN SPEC 70121:2014
#2	1.0.0	2014	Requirements System	IEC61851-23 Ed1:2014
#3	3.0.0	2017	Requirements System	IEC61851-1 Ed3:2017

#4	0.9.5	04.11.2019	Comm Guide	CharIN Implementation Guide to DIN SPEC 70121:2014
#5	1.2.0	07/2021	System and PWM Guide	CharIN IEC61851-23:2014 – Implementation guide for system C
#6	1.0.0	2018	Test Cases Comm	DIN SPEC 70122 Ed1:2018
#7	1.1.3	03/2022	Test Cases Comm Guide	CharIN Test Cases for DIN SPEC 70121:2014 Implementation Guide
#8	1.0.1	03/2022	Test Cases System, PWM and Power	CharIN EVSE Test Cases for DC charging with system C according to IEC 61851-1 and IEC 61851-23
#9	6.0.0	24.06.2018	Requirements Power	CharIN DC CCS Power Classes
#10	1.0.0	2018	Requirements and Test EMC	IEC61851-21-2:2018
#11	4	2021	Vehicle Coupler Tests	CharIN Conformance Tests – Vehicle Coupler Version 4

Table 3 – Test Case version numbering

For the CharIN Conformance Test Label the numbers reference a certain version of a document, Combo1 vs. Combo2 vehicle coupler and the Power Class of the charger.

Combo1 is the vehicle coupler IEC62196-3 Configuration EE

Combo2 is the vehicle coupler IEC62196-3 Configuration FF

CharIN DC Basic EVSE “Coupler” “PowerClass” v_”#1_#2_#3_#4_#5_#6_#7_#8_#9_#10_#11”

E.g.

“CharIN DC Basic EVSE Combo2 FC50

v_1.0.0_1.0.0_3.0.0_0.9.5_1.2.0_1.0.1_1.1.3_1.0.0_6.0.0_1.0.0_4”

approved

When new versions of documents with new revision numbers get published the number in the CharIN Conformance Test Label must be adjusted.

3.1.2. CharIN Conformance Test Label

For better readability a reduced numbering scheme based on certain baselines are used for public conformance test label.

Date	Conformance Test Baseline version #	Conformance Test Document revision used for Baseline version
17.03.2022	1.1.6	1.0.0_1.0.0_3.0.0_0.9.5_1.2.0_ 1.0.1_1.1.3_1.0.0_6.0.0_1.0.0_4

Table 4 – CT Baseline version

CharIN DC Basic EVSE “Coupler” “PowerClass” “Baseline version” approved

E.g. a EVSE would get the following label

“CharIN DC Basic EVSE Combo2 FC50 v1.1.6 approved”

When a new baseline for Conformance Test is created the number in the CharIN Conformance Test Label must be adjusted.

3.1.3. Guideline for test verdict to obtain robust test results

Handling of “Inconclusive” test result:

In CharIN Conformance testing, an “Inconclusive” verdict is not allowed. An “Inconclusive” test result might be created when:

- Certain parameters of the Test Case implementation affect the test results, for instance, timing parameters of CP state changes. In that case, the Test Case implementation needs to be revised against the behavior of the specific SUT.

- There are issues with the set or measurement tolerance, accuracy, or uncertainty, for instance if a measured test parameter (such as timing, or duty cycle) is close to the boundary between a pass and fail value. In that case, the set/measurement tolerance of the test system might be adjusted, or the implementation of the SUT might be adjusted to be more robust against testing.
- The test configuration is incorrect, i.e. PIXIT, PICS

If testers take “Inconclusive” test result, deeper analysis is required and more test trials are allowed. After 3 trials, if the test result is still “Inconclusive”, it shall be treated as “Failed” verdict.

Regarding tolerance, accuracy, uncertainty issues, it shall be processed with QAP of testing houses, which has been certified by ISO 17025 or ISO 9001.

If testers find any test objective issue, they have the main duty to report it to the CharIN Focus Group Conformance test/Interoperability and support the activities to resolve the issue.

Handling of “Sporadic” errors (e.g. charging stop during reliability test):

Sporadic errors during Test Case execution may occur. Deeper analysis is allowed and Test Cases may be repeated 3 times to resolve sporadic issues.

If a Test Case fails the 3rd time (e.g. SUT still makes the sporadic charging stop) the whole test verdict shall be treated as “Failed” and a new HW/SW must be provided.

Example: The Test Case “CharIN_TC_SECC_VTB_Reliability_001” is testing 20 x 2 Min charging.

If the 1st run with 20 charging cycles is failed, it is possible to run the 20 charging cycles another two times. If none of the three runs of 20 charging cycles is passed the Test Case verdict is “Failed”.

3.1.4. Guideline for power flow configuration of communication test

If there is no clear direction in Test Case for power flow configuration during CurrentDemand routine, testers should set as follows;

- Current: Mid value of Min. and Max. of SUT (in ChargeParameterDiscovery)
- Battery simulation voltage (V1): Mid value of Min. and Max. of SUT (in ChargeParameterDiscovery)

3.2. Conformance Test for DC Charging System Basic EVSEs

An EVSE supporting DC Charging System Basic must pass the following mandatory Test Cases to gain a DC Charging System Basic EVSE compliance certificate.

The first version of CharIN Test Cases focusses on interoperability instead of full standard conformity. This means

- sending of messages should be as standard conform as possible.
- receiving messages should be robust against wrong but uncritical parameters.

The following Test Case lists contain Priority of Test Cases with Prio 1-3.

Prioritization of Test Cases is based on

- robustness (good case higher priority than error cases)
- criticality of error (e.g. safety has highest priority)
- possibility of occurrence in field and

Prioritization could be used to focus on most important Test Cases if test time is limited.

But all Test Cases Prio 1, Prio 2 and Prio 3 must be passed to receive a DC Charging System Basic EVSE compliance certificate from CharIN.

The following Test Case lists contain the parameter Mandatory (Mand) or Optional (Opt):

Mandatory:

Test needs to be executed and passed to receive CharIN Charging System Basic V1.1.5 certificate for DC Charging System Basic EVSE (i.e. CharIN Charging System Basic V1.1.5 certificate).

Optional:

Test needs to be executed but the verdict has no influence on whether the CharIN Charging System Basic V1.1.5 certificate is provided or not (informative test).

All DC Charging System Basic EVSE test cases should be carried out using the test methods described in clause 102 of IEC 61851-23 including details about

- mandatory technical details
- environmental test conditions
- test power requirements
- measuring instruments

- test setups for system A,B and C
- test load
- operating points for tests

3.2.1. DIN SPEC 70122:2018 DC EVSE Basic Test cases

An EVSE supporting DC Charging System Basic must pass all of the following mandatory Test cases from “DIN SPEC 70122:2018” to receive a DC Charging System Basic EVSE compliance certificate from CharIN.

For optional functions PIXIT must be considered.

E.g. a EVSE only supporting DIN SPEC 70121 must pass other Test cases then a EVSE supporting DIN SPEC 70121 and ISO 15118.

For more details on PIXIT see sub documents.

TC Nr	Test case Identifier	Comment	Prio	PIXIT/Comment
1	TC_SECC_VTB_CmSlacParm_004	Check for crosstalk/CP State A	2	Mandatory
2	TC_SECC_VTB_AttenuationCharacterization_002	2 nd SLAC request from same instance	3	Mandatory
3	TC_SECC_VTB_CmValidate_001	Good case	3	Mandatory
4	TC_SECC_VTB_CmValidate_002	Check repetition	3	Mandatory
5	TC_SECC_VTB_CmValidate_012	SLAC_MATCH check	3	Mandatory PIXIT_SECC_CmValidate := cmValidate, PIXIT_SECC_ArchitectureValidationNotRequired := true
6	TC_SECC_VTB_CmSlacMatch_001	Good case, No validation	1	Mandatory
7	TC_SECC_VTB_CmSlacMatch_002	Good case, with validation	3	Mandatory
8	TC_SECC_VTB_PLCLinkStatus_001	Good case	1	Mandatory

9	TC_SECC_VTB_V2GTPSessionSetup_001	Good case	1	Mandatory
10	TC_SECC_VTB_V2GTPSDP_001	Good case	1	Mandatory
11	TC_SECC_VTB_SupportedAppProtocol_001 TC_SECC_CMN_VTB_SupportedAppProtocol_001	Good case	1	Mandatory
12	TC_SECC_VTB_SupportedAppProtocol_002 TC_SECC_CMN_VTB_SupportedAppProtocol_002	Wrong namespace	3	Mandatory
13	TC_SECC_VTB_SupportedAppProtocol_003 TC_SECC_CMN_VTB_SupportedAppProtocol_003	Timeout check	3	Mandatory
14	TC_SECC_VTB_SupportedAppProtocol_005 TC_SECC_CMN_VTB_SupportedAppProtocol_004	Minor Version difference	2	Mandatory
15	TC_SECC_VTB_SessionSetup_003 TC_SECC_CMN_VTB_SessionSetup_003	Timeout 60s	3	Mandatory
16	TC_SECC_VTB_ServiceDiscovery_001 TC_SECC_CMN_VTB_ServiceDiscovery_001	Good case	1	Mandatory
17	TC_SECC_VTB_ServiceDiscovery_002 TC_SECC_CMN_VTB_ServiceDiscovery_002	Sequence error	3	Mandatory
18	TC_SECC_VTB_ServiceDiscovery_004 TC_SECC_CMN_VTB_ServiceDiscovery_003	Timeout 60s	3	Mandatory

19	TC_SECC_VTB_ServiceDiscovery_005 TC_SECC_CMN_VTB_ServiceDiscovery_004	Charging end	1	Mandatory
20	TC_SECC_VTB_ServicePaymentSelection_001 TC_SECC_CMN_VTB_PaymentServiceSelection_001	Good case	1	Mandatory
21	TC_SECC_VTB_ServicePaymentSelection_002 TC_SECC_CMN_VTB_PaymentServiceSelection_004	Sequence error	3	Mandatory
22	TC_SECC_VTB_ServicePaymentSelection_005 TC_SECC_VTB_ServiePaymentSelection_005	Timeout 60s	3	Mandatory
23	TC_SECC_VTB_ServicePaymentSelection_007 TC_SECC_CMN_VTB_PaymentServiceSelection_009	PnC check	3	Mandatory
24	TC_SECC_VTB_ContractAuthentication_001	Good case	1	Mandatory
25	TC_SECC_VTB_ContractAuthentication_002	Sequence error	3	Mandatory
26	TC_SECC_VTB_ContractAuthentication_004	Timeout 60s	3	Mandatory
27	TC_SECC_VTB_ContractAuthentication_006	Ongoing	2	Mandatory
28	TC_SECC_VTB_ChargeParameterDiscovery_003 TC_SECC_DC_VTB_ChargeParameterDiscovery_002	Sequence error	3	Mandatory

29	TC_SECC_VTB_ChargeParameterDiscovery_004 TC_SECC_DC_VTB_ChargeParameterDiscovery_003	Wrong Energy Transfer Type	1	Mandatory
30	TC_SECC_VTB_ChargeParameterDiscovery_005 TC_SECC_DC_VTB_ChargeParameterDiscovery_004	-100A max	3	Mandatory
31	TC_SECC_VTB_ChargeParameterDiscovery_006	Timeout 60s	3	Mandatory
32	TC_SECC_VTB_CableCheck_003 TC_SECC_DC_VTB_CableCheck_003	Sequence error	3	Mandatory
33	TC_SECC_VTB_CableCheck_005 TC_SECC_DC_VTB_CableCheck_005 Timeout defined as V2G_SECC_Sequence_Timeout in Table 109	Timeout, 60s	3	Mandatory
34	TC_SECC_VTB_PreCharge_001 TC_SECC_DC_VTB_PreCharge_001	Good case	1	Mandatory
35	TC_SECC_VTB_PreCharge_002 TC_SECC_DC_VTB_PreCharge_002	Sequence Error	3	Mandatory
36	TC_SECC_VTB_PreCharge_004 TC_SECC_DC_VTB_PreCharge_004	Timeout 60s	3	Mandatory
37	TC_SECC_VTB_PreCharge_005	State B	1	Mandatory
38	TC_SECC_VTB_PreCharge_006	Stop communication	1	Mandatory
39	TC_SECC_VTB_PowerDelivery_001 TC_SECC_DC_VTB_PowerDelivery_001	Good case before CurrentDemand	1	Mandatory

40	TC_SECC_VTB_PowerDelivery_002 TC_SECC_DC_VTB_PowerDelivery_002	Good case after CurrentDemand	1	Mandatory
41	TC_SECC_VTB_PowerDelivery_003 TC_SECC_DC_VTB_PowerDelivery_003	Sequence error	3	Mandatory
42	TC_SECC_VTB_PowerDelivery_004 TC_SECC_DC_VTB_PowerDelivery_004	Sequence error	3	Mandatory
43	TC_SECC_VTB_PowerDelivery_006 TC_SECC_DC_VTB_PowerDelivery_006	RtC=false	3	Mandatory
44	TC_SECC_VTB_PowerDelivery_010 TC_SECC_DC_VTB_PowerDelivery_009	Timeout 60s	3	Mandatory
45	TC_SECC_VTB_CurrentDemand_002 TC_SECC_DC_VTB_CurrentDemand_003	Sequence error	3	Mandatory
46	TC_SECC_VTB_CurrentDemand_004 TC_SECC_DC_VTB_CurrentDemand_005	Timeout 60s	3	Mandatory
47	TC_SECC_VTB_WeldingDetection_002 TC_SECC_DC_VTB_WeldingDetection_002	Sequence error	3	Mandatory
48	TC_SECC_VTB_SessionStop_001 PICS_SECC_WeldingDetection := false is NOT a PIXIT and is only the configuration of the test system. This Test Case is always mandatory.	Good case	1	Mandatory

	<p>NOTE: EVSE must process charging session with & without welding detection (PICS_SECC_WeldingDetection := true & PICS_SECC_WeldingDetection := false)</p> <p>TC_SECC_DC_VTB_SessionStop_001</p>			
49	<p>TC_SECC_VTB_SessionStop_002 TC_SECC_DC_VTB_SessionStop_002</p>	<p>Good case PICS=true</p>	1	Mandatory
50	<p>TC_SECC_VTB_SessionStop_003</p> <p>PICS_SECC_WeldingDetection := false is NOT a PIXIT and is only the configuration of the test system. This Test Case is always mandatory.</p> <p>NOTE: EVSE must process charging session with & without welding detection (PICS_SECC_WeldingDetection := true & PICS_SECC_WeldingDetection := false)</p> <p>TC_SECC_DC_VTB_SessionStop_003</p>	<p>Sequence error</p>	3	Mandatory
51	<p>TC_SECC_VTB_SessionStop_005</p> <p>PICS_SECC_WeldingDetection := false is NOT a PIXIT and is only the configuration of the test system. This Test Case is always mandatory.</p>	<p>Timeout 60s</p>	2	Mandatory

	<p>NOTE: EVSE must process charging session with & without welding detection (PICS_SECC_WeldingDetection := true & PICS_SECC_WeldingDetection := false)</p> <p>Update test objective:</p> <p>Replace</p> <p>Test System executes GoodCase procedure without welding detection process and waits until the 'V2G_Sequence_Timeout' timer has expired after receiving a PowerDeliveryRes message with the current SessionID, ResponseCode 'OK', EVSEStatusCode 'EVSE_Ready' and all additional mandatory parameters.</p> <p>By</p> <p>Test System executes GoodCase procedure and stops the charging process by sending a PowerDeliveryReq message with the current sessionID, ReadyToChargeState 'false' and all additional</p>			
--	---	--	--	--

	<p>mandatory parameters. After receipt of PowerDeliveryRes message with the current SessionID, ResponseCode 'OK', EVSEStatusCode 'EVSE_Ready' and all additional mandatory parameters, Test System waits until the 'V2G_Sequence_Timeout' timer has expired.</p> <p>TC_SECC_DC_VTB_SessionStop_005</p>			
52	<p>TC_SECC_VTB_SessionStop_006 TC_SECC_DC_VTB_SessionStop_007</p>	Sequence error	3	Mandatory
53	<p>TC_SECC_VTB_SessionStop_009</p> <p>PICS_SECC_WeldingDetection := false is NOT a PIXIT and is only the configuration of the test system. This Test Case is always mandatory.</p> <p>NOTE: EVSE must process charging session with & without welding detection (PICS_SECC_WeldingDetection := true & PICS_SECC_WeldingDetection := false)</p> <p>Update test objective:</p> <p>Replace</p> <p>Test System executes GoodCase procedure, signals no CP State B after receipt of a valid PowerDeliveryReq message and sends a SessionStopReq</p>	State B	2	Mandatory

	<p>message with the current SessionID and all additional mandatory parameters.</p> <p>By</p> <p>Test System executes GoodCase procedure, signals no CP State B after receipt of a valid PowerDeliveryRes message and sends a SessionStopReq message with the current SessionID and all additional mandatory parameters.</p>			
54	TC_SECC_VTB_IOP_SDP_003	ISO15118 IOP	2	Mandatory PIXIT_CMN_IOP_TLS := tls, PIXIT_CMN_IOP_ProtocolSupport := dinAndIso
55	TC_SECC_VTB_IOP_SDP_004	ISO15118 IOP	2	Mandatory
56	TC_SECC_VTB_IOP_SupportedAppProtocol_001 TC_SECC_CMN_VTB_SupportedProtocol_001	ISO15118 IOP	2	Mandatory PIXIT_CMN_IOP_ProtocolSupport := dinAndIso
57	TC_SECC_VTB_IOP_SupportedAppProtocol_002	ISO15118 IOP	2	Mandatory PIXIT_CMN_IOP_ProtocolSupport := dinAndIso

Table 5 - DIN 70121 Test cases

3.2.2. “Test Cases for DIN SPEC 70121:2014 Implementation Guide” DC EVSE Basic Test cases

An EVSE supporting DC Charging System Basic must pass all of the following Test cases from “Test Cases for DIN SPEC 70121:2014 Implementation Guide” document to receive DC Charging System Basic EVSE compliance certificate from CharIN.

For optional functions PIXIT must be considered. For more details see sub documents.

TC Number	Test case Identifier	Comment	Prio	PIXIT/Comment
500	CharIN_TC_SECC_VTB_PSDMeasurement_001	PSD check	1	Mandatory
501	CharIN_TC_SECC_VTB_CmSlacParm_001	Good case	1	Mandatory
502	CharIN_TC_SECC_VTB_CmSlacParm_006	GreenyPhy ready at 5%	1	Mandatory
503	CharIN_TC_SECC_VTB_CmSlacParm_007	19s SLAC Req delay	1	Mandatory
504	CharIN_TC_SECC_VTB_AttenuationCharacterization_001	Good case	1	Mandatory
505	CharIN_TC_SECC_VTB_AttenuationCharacterization_003	9 Sound packets	3	Mandatory
506	CharIN_TC_SECC_VTB_AttenuationCharacterization_004	Timeout	2	Optional
507	CharIN_TC_SECC_VTB_AttenuationCharacterization_019 Replace (The mean of the attenuation values of test run 1 should be at least 'par_SECC_attenuationDeviation')	Check Atten measurement of EVSE	1	Mandatory

	<p>smaller than the mean of the attenuation values of test run 2).</p> <p>By</p> <p>(The mean of the attenuation values of test run 1 should be at least 'par_SECC_attenuationDeviation' smaller than the mean of the attenuation values of test run 2).</p> <p>NOTE: 'par_SECC_attenuationDeviation' equals to 7dB. This parameter should be added to Table 9 in CharIN Test Cases for DIN SPEC 70121:2014 Implementation Guide</p>			
508	<p>CharIN_TC_SECC_VTB_Attenuation Characterization_020</p> <p>PSD calibration report needed</p>	<p>Check for 23dB min.</p>	3	Optional
509	<p>CharIN_TC_SECC_VTB_CmValidate_010</p>	<p>Check for PIXIT</p>	3	Mandatory
510	<p>CharIN_TC_SECC_VTB_PLCLinkStatus_004</p>	<p>SLAC request with existing link</p>	2	Mandatory
511	<p>CharIN_TC_SECC_VTB_PLCLinkStatus_005</p> <p>Replace</p> <p>Test System executes GoodCase procedure and initiates a terminated V2G communication session by</p>	<p>HPGP Leave after SessionStop</p>	3	Mandatory

	<p>sending a SessionStopReq message with the current SessionID, ChargingSession 'Terminate' and all additional mandatory parameters and waits for a SessionStopRes message with the current SessionID and all additional mandatory parameters. Furthermore Test System checks if the SUT initiates an oscillator shutdown and terminates the TCP connection after successful charging process. Test System then checks that the SUT leaves the logical network by using the CM_NW_STATS message sequence after the 'T_match_leave' timer has expired.</p> <p style="text-align: center;">By</p> <p>Test System executes GoodCase procedure and initiates a terminated V2G communication session by sending a SessionStopReq message with the current SessionID and all additional mandatory parameters and waits for a SessionStopRes message with the current SessionID and all additional mandatory parameters. Furthermore Test System checks if the SUT initiates an oscillator shutdown and terminates the TCP connection after successful charging process. Test System then checks that the SUT terminates the data link connection (SUT shall set new NMK) using a link loss detection</p>			
--	--	--	--	--

	mechanism for the local Green PHY node. NOTE: Also relevant for CharIN_TC_EVCC_VTB_PLCLinkStatus_003			
512	CharIN_TC_SECC_VTB_SDP_005	ISO15118 IOP	2	PIXIT_CMN_IOP_ProtocolSupport := din
513	CharIN_TC_SECC_VTB_SupportedAppProtocol_004	CommunicationSetup Timer check	3	Mandatory
514	CharIN_TC_SECC_VTB_SessionSetup_001	Good case	1	Mandatory
515	CharIN_TC_SECC_VTB_SessionSetup_005	SessionID not 0	3	Mandatory
516	CharIN_TC_SECC_VTB_SessionSetup_006	SessionID not 0	3	Mandatory
517	CharIN_TC_SECC_VTB_SessionSetup_007	SessionID not 0	3	Mandatory
518	CharIN_TC_SECC_VTB_ServiceDiscovery_009	ServiceCategory ignored	3	Mandatory
519	CharIN_TC_SECC_VTB_ContractAuthentication_008	Ongoing Timeout	3	Mandatory
520	CharIN_TC_SECC_VTB_ChargeParameterDiscovery_001	Good Case	1	Mandatory
521	CharIN_TC_SECC_VTB_ChargeParameterDiscovery_010	Data type check	2	Mandatory
522	CharIN_TC_SECC_VTB_ChargeParameterDiscovery_011	Data type check	2	Optional
523	CharIN_TC_SECC_VTB_ChargeParameterDiscovery_012	Data type check	2	Mandatory

524	CharIN_TC_SECC_VTB_ChargeParameterDiscovery_013	Ongoing Timeout	3	Optional PIXIT_SECC_ChargeParameterDiscoveryOngoing := ongoing
525	CharIN_TC_SECC_VTB_ChargeParameterDiscovery_014	Data type check	3	Mandatory PIXIT_SECC_ChargeParameterDiscoveryOngoing := unknown, PIXIT_SECC_EVSEMaximumPowerLimitValue
526	CharIN_TC_SECC_VTB_ChargeParameterDiscovery_015	Data type check	3	Mandatory PIXIT_SECC_ChargeParameterDiscoveryOngoing := unknown, PIXIT_SECC_EVSEMaximumVoltageLimitValue
527	CharIN_TC_SECC_VTB_ChargeParameterDiscovery_016	Data type check	3	Mandatory PIXIT_SECC_ChargeParameterDiscoveryOngoing := unknown, PIXIT_SECC_EVSEMaximumCurrentLimitValue
528	CharIN_TC_SECC_VTB_ChargeParameterDiscovery_017	32kW max check	3	Mandatory PIXIT_SECC_ChargeParameterDiscoveryOngoing:=unknown, PIXIT_SECC_EVSEMaximumCurrentLimitValue <= 32678W
529	CharIN_TC_SECC_VTB_ChargeParameterDiscovery_018	32kW max check	3	Mandatory PIXIT_SECC_ChargeParameterDiscoveryOngoing

				going:=unknown, PIXIT_SECC_EVSEMaximumCurrentLimitValue > 32678W
530	CharIN_TC_SECC_VTB_CableCheck_001	Good case	1	Mandatory PIXIT_SECC_CableCheckOngoing := unknown
531	CharIN_TC_SECC_VTB_CableCheck_002	CP State D, ongoing	3	Mandatory PIXIT_SECC_CableCheckOngoing := unknown
532	CharIN_TC_SECC_VTB_CableCheck_007	FAILED_RESSTemperatureInhibit'	3	Mandatory
533	CharIN_TC_SECC_VTB_CableCheck_008	FAILED_EVShiftPosition	3	Mandatory
534	CharIN_TC_SECC_VTB_CableCheck_009	FAILED_ChargerConnectorLockFault	3	Mandatory
535	CharIN_TC_SECC_VTB_CableCheck_010	FAILED_EVRESSMalfunction'	3	Mandatory
536	CharIN_TC_SECC_VTB_CableCheck_011	'FAILED_ChargingCurrentdifferential'	3	Mandatory
537	CharIN_TC_SECC_VTB_CableCheck_012	'FAILED_ChargingVoltageOutOfRange'	3	Mandatory

538	CharIN_TC_SECC_VTB_CableCheck_013	'FAILED_ChargingSystemIncompatibility'	3	Mandatory
539	CharIN_TC_SECC_VTB_CableCheck_014	EVErrorCode 'NoData'	3	Mandatory
540	CharIN_TC_SECC_VTB_CableCheck_016	Ongoing, EVReady=False	1	Mandatory
541	CharIN_TC_SECC_VTB_CableCheck_017	Ongoing, EVReady=true	1	Mandatory
542	CharIN_TC_SECC_VTB_CableCheck_018	Ongoing	2	Mandatory
543	CharIN_TC_SECC_VTB_CableCheck_020	Ongoing	2	Mandatory
544	CharIN_TC_SECC_VTB_CableCheck_021	Ongoing	2	Mandatory
545	CharIN_TC_SECC_VTB_CableCheck_022	State D Ongoing	3	Mandatory
546	CharIN_TC_SECC_VTB_CableCheck_024	EVErrorCode check	3	Mandatory
547	CharIN_TC_SECC_VTB_PreCharge_009	EVTargetCurrent=0	2	Mandatory
548	CharIN_TC_SECC_VTB_PowerDelivery_015	Ignore ChargingProfile	2	Mandatory
549	CharIN_TC_SECC_VTB_CurrentDemand_001	Good case	1	Mandatory

550	CharIN_TC_SECC_VTB_CurrentDem and_011	0A	2	Mandatory PIXIT_SECC_EVSEMaximumPowerLimit := eVSEMaximumPowerLimit, PIXIT_SECC_EVSEMaximumPowerLimitValue
551	CharIN_TC_SECC_VTB_CurrentDem and_012	Data type check	2	Mandatory
552	CharIN_TC_SECC_VTB_CurrentDem and_013	Data type check	2	Mandatory
553	CharIN_TC_SECC_VTB_CurrentDem and_015	Data type check	2	Mandatory
554	CharIN_TC_SECC_VTB_CurrentDem and_016	Data type check	2	Mandatory
555	CharIN_TC_SECC_VTB_IOP_CmSlac Parm_001	ISO15118 IOP State B, 19s wait	2	Mandatory PIXIT_SECC_IOP_PWM := dc100, PIXIT_CMN_IOP_ProtocolSupport := dinAndIso
556	CharIN_TC_SECC_VTB_IOP_CmSlac Parm_004	ISO15118 IOP State B, 19s wait	2	Mandatory PIXIT_SECC_IOP_PWM := unknown, PIXIT_CMN_IOP_ProtocolSupport := dinAndIso
557	CharIN_TC_SECC_VTB_IOP_SDP_00 1	ISO15118 IOP Security=0x00 TCP=0x00	2	Mandatory PIXIT_CMN_IOP_TLS := tls, PIXIT_CMN_IOP_ProtocolSupport := dinAndIso

558	CharIN_TC_SECC_VTB_IOP_SDP_002	ISO15118 IOP Security=0x10 TCP=0x00	2	Mandatory PIXIT_CMN_IOP_TLS := none, PIXIT_CMN_IOP_ProtocolSupport := dinAndIso
559	CharIN_TC_SECC_VTB_IOP_SDP_005	ISO15118 IOP Security=0x10 TCP=0x00	2	Mandatory PIXIT_CMN_IOP_TLS := tls, PIXIT_CMN_IOP_ProtocolSupport := dinAndIso
560	CharIN_TC_SECC_VTB_IOP_SupportedAppProtocol_003	ISO15118 IOP 20 namespaces	2	Mandatory PIXIT_CMN_IOP_ProtocolSupport := din
561	CharIN_TC_SECC_VTB_CmValidate_003	Timeout Retry check	3	Mandatory PIXIT_SECC_CmValidate := cmValidate
562	CharIN_TC_SECC_VTB_Reliability_001	20x 2 mins charging	2	Mandatory
563	CharIN_TC_SECC_VTB_Reliability_002	2 x 15 mins charging	2	Mandatory
564	CharIN_TC_SECC_VTB_Reliability_003	1 x 45mins charging	2	Mandatory
565	CharIN_TC_SECC_VTB_SDP_006	50 repetitions	2	Mandatory
566	CharIN_TC_SECC_VTB_SDP_007	20s Timeout	2	Mandatory
567	CharIN_TC_SECC_VTB_PLCLinkStatus_002	New key after plug out check	1	Mandatory
568	CharIN_TC_SECC_VTB_PowerDelivery_009	Timeout 60s	3	Mandatory
569	CharIN_TC_SECC_VTB_WeldingDetection_004	Timeout 60s	3	Mandatory
570	CharIN_TC_SECC_VTB_WeldingDetection_005	State B	2	Mandatory

571	CharIN_TC_SECC_VTB_WeldingDetection_001	Good Case	1	Mandatory
572	CharIN_TC_SECC_VTB_PLCLinkStatus_004	SLAC request with existing link	2	Mandatory
573	TC_SECC_VTB_ChargeParameterDiscovery_001	Good case	1	Mandatory

Table 6 - DIN 70121 Guide Test cases

3.2.3. IEC 61851-1 DC Charging System Basic EVSE Test cases

An EVSE supporting DC Charging System Basic must pass all of the following Test cases for IEC 61851-1 from “CharIN EVSE Test Cases for DC charging with system C according to IEC 61851-1 and IEC 61851-23” document to receive CharIN DC Charging System Basic EVSE compliance certificate from CharIN.

TC Number	Test Case Identifier	Comment	Prio	Remark
1000	EVSE_DC_state_detection_C_upper_tolerance	State C tolerance	2	Mand
1001	EVSE_DC_state_detection_C_lower_tolerance	State C tolerance	2	Mand
1002	EVSE_DC_CP+PP_check_OutputLow_StateC	CP parameter check lo	1	Mand
1003	EVSE_DC_CP+PP_check_OutputHigh_StateC	CP parameter check high	1	Mand
1004	EVSE_DC_no_stateF_by_BCB-state-change	No State F sequence	2	Optional
1005	EVSE_DC_20_charging_attempts	Robustness	1	Mand
1006	EVSE_DC_CP_circuit_state_C_OutputHigh	Robustness charging	1	Mand
1007	EVSE_DC_CP_circuit_state_C_OutputLow	Robustness charging	1	Mand
1008	EVSE_DC_min-max_CP-state_tolerances	Min/Max Tolerances	2	Mand

Table 7 – IEC 61851-1 Test Cases

3.2.4. IEC 61851-23 DC Charging System Basic EVSE Test Cases

An EVSE supporting DC Charging System Basic must pass all of the following Test Cases for IEC61851-23 from “CharIN EVSE Test Cases for DC charging with system C according to IEC 61851-1 and IEC 61851-23” document to receive DC Charging System Basic EVSE compliance certificate from CharIN.

TC Number	Test Case Identifier	Comment	Prio	Remark
2000	CC.7.5.15.6	Asym fault -	1	Optional
2001	CC.7.5.15.6	Asym fault +	1	Optional
2002	CC.7.5.15.6	Sym fault	1	Optional
2003	CC.7.5.16.6	Asym fault -	1	Optional
2004	CC.7.5.16.6	Asym fault +	1	Optional
2005	CC.7.5.16.6	Sym fault	1	Mand
2006	EVSE_DC_CCS_PowerClass_assignment	Power Class	1	Mandatory
2007	Figure CC.9?	EV emergency shutdown	1	Mand
2008	CC.7.5.1.6	VEVSE min/max check	2	Mand
2009	DD.2 -- ?	Reverse Power Flow prevention	2	Optional
2010		Current regulation static	1	Optional

	CC.7.5.11.7			
2011	CC.7.5.13.7	PreCharge regulation	2	Mand
2012	CC.7.5.11.7	Current regulation dynamic	2	Optional
2013	CC.7.5.14.7	Current regulation max	2	Optional
2014	CC.7.5.14.7	Emerg shutdown for CP - PE shortcut	1	Mand
2015	CC.7.5.7	Emerg shutdown for overvoltage	2	Optional
2016	CC.7.5.9.7	Voltage overshoot limit load dump	2	Mand
2017	CC. 7.5.6	Datasheet check min/max values	2	Optional
2018	CC.7.5.8	Emerg shutdown PP loss EV	1	Optional
2019	CC.4.5?	CableCheck voltage check	2	Mand
2020	CC.7.5.4.6	CP loss shutdown in CableCheck	1	Mand
2021	CC.7.5.4.6	CP loss shutdown in PreCharge	1	Mand

2022	CC.7.5.4.6	CP loss shutdown in CurrentDemand	1	Mand
2023	CC.7.5.15.6	Asym valid -	2	Mand
2024	CC.7.5.15.6	Asym valid +	2	Mand
2025	CC.7.5.15.6	Sym valid	2	Mand
2026	CC.7.5.16.6	Asym valid -	2	Mand
2027	CC.7.5.16.6	Asym valid +	2	Mand
2028	CC.7.5.16.6	Sym fault	2	Mand

Table 8 – IEC 61851-23 Test Cases

3.2.5. IEC 61851-21-2 DC Charging System Basic EVSE Test Cases (EMC)

IEC 61851-21-2 Part 21-2: “Electric vehicle requirements for conductive connection to an AC/DC supply – EMC requirements for off-board electric vehicle charging systems”

gives requirement on EMC for DC EVSEs.

Conducted emission on DC+/DC- can disturb PLC communication on Control Pilot Line by crosstalk. This was already seen in field. Charging errors because of charger EMC noise.

Chapter 6 in IEC 61851-21-2:2018 gives emission requirements.

Table 12 specifies max level for disturbance voltage limits on the DC lines.

TC Number	Test Case Identifier	Comment	Prio	Remark
4000	CharIN_TC_SECC_V TB-EMC-001	An EVSE supporting DC Charging System Basic must fulfill the limits for disturbance voltage limits in table 12 of IEC61851-21-2:2018 to receive DC Charging System Basic EVSE compliant certificate.	1	Mandatory

Table 9 – EMC Test Cases

The limits are given for “Rated power of ≤ 75 kVA” and “Rated power of > 75 kVA”.

But field experience show that limits for “Rated power of > 75 kVA” are not sufficient to protect the PLC communication on the Control pilot line. Therefore CharIN recommends to provide means like shielded cables for Control Pilot, certain filtering ... to protect the PLC Communication on the Control Pilot Line against noise from power electronics of the EVSE.

This tests might not be done by the CCTS or a CharIN Testing house but by a specialized EMC lab.

The Test Report has to be provided to CharIN for receive DC Charging System Basic EVSE compliant certificate for each Coupler/Cable of the charger. E.g. if it is a dual charger with Combo1 and Combo2 coupler the test report must be provided for both interfaces.

3.2.6. IEC 62196 Vehicle Coupler Test Cases

IEC 62196-1/-2 and -3 specify requirements for vehicle connector and inlets.

For interoperability it must be assured that the vehicle connector fits into the vehicle inlet and locking works properly.

TC Number	Test Case Identifier	Comment	Prio	Remark
5000	CharIN_TC_SECC_VTB-CON-001	<p>An EVSE supporting DC Charging System Basic must fulfill the requirements of IEC 62196-1, -2 and -3.</p> <p>An IEC / IECEE Test Report (CB Scheme) must be provided to Test House to receive DC Charging System Basic EVSE compliant certificate.</p>	1	Mandatory

Table 10 – Coupler Test Cases

This tests might not be done by the CCTS or a CharIN Testing house but by a specialized mechanical/coupler lab.

The Test Report has to be provided to CharIN for receive DC Charging System Basic EVSE compliant certificate for each Coupler/Cable of the charger. E.g. if it is a dual charger with Combo1 and Combo2 coupler the test report must be provided for both interfaces.

3.3. Requirements for Test Systems (CCTS)

To assure comparable test results over different Test Systems (CCTS) CharIN has set up a Qualification Process for Test Systems. For details see CharIN “Quality Assurance Plan (QAP) for CharIN Conformance testing of Charging System”.

3.4. Requirements for Testing houses

To assure comparable test results over different Testing houses CharIN setup a Qualification Process for Testing houses. For details see CharIN “Quality Assurance Plan (QAP) for CharIN Conformance testing of Charging System”.



4. Reference

This document was created by the FG Conformance Test & IOP of the CharIN association.